

#	TOP OPTIONS
<input type="checkbox"/> 1	SLOPE TOP NO TOP LIFT INSERTS
<input type="checkbox"/> 2	SLOPE TOP WITH TOP LIFT
<input type="checkbox"/> 3	SLOPE TOP NO TOP LIFT
<input type="checkbox"/> 4	12" FILLNECK WITH HEAVY LIFT
<input type="checkbox"/> 5	SLOPE TOP SANITARY WITH TOP LIFT
<input type="checkbox"/> 6	SLOPE TOP SANITARY NO TOP LIFT
<input type="checkbox"/> 7	SLOPE TOP SANITARY NO TOP LIFT INSERTS
<input type="checkbox"/> 8	OPEN TOP

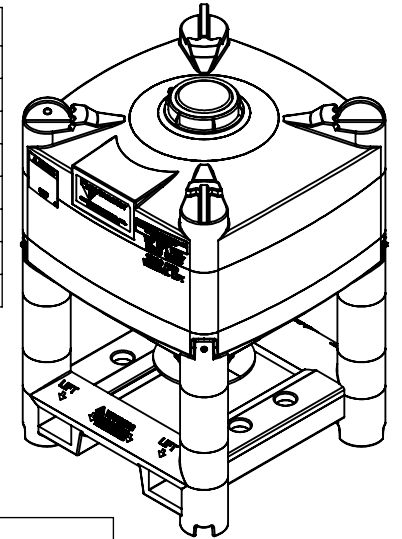

SIZE	(A) OVERALL HEIGHT	(B) NESTING HEIGHT
<input type="checkbox"/> 25CF	56.6"	51.6"
<input type="checkbox"/> 40CF	69.2"	64.2"
<input type="checkbox"/> 50CF	76.2"	71.2"
<input type="checkbox"/> 60CF	86.3"	81.3"
<input type="checkbox"/> 70CF	93.2"	88.2"
<input type="checkbox"/> 80CF	102.4"	97.4"
MAX HEIGHT FOR SHIPPING IS 106"		

OUTLET OPTIONS	
<input type="checkbox"/>	Ø4" FLANGED
<input type="checkbox"/>	Ø8" FLANGED
<input type="checkbox"/>	Ø12" FLANGED
<input type="checkbox"/>	UNTRIMMED

STAND OPTIONS	
<input type="checkbox"/>	SANITARY
<input type="checkbox"/>	ORIGINAL
<input type="checkbox"/>	NO STAND

ADDITIONAL OPTIONS	
<input type="checkbox"/>	SANITARY FINISH PROCESS
<input type="checkbox"/>	CUSTOM MARKINGS
<input type="checkbox"/>	CUSTOM LOGO
<input type="checkbox"/>	PROTECTIVE WRAP

ADDITIONAL COMPONENTS

QTY	P/N	DESCRIPTION

ALL DIMENSIONS ARE IN INCHES, NOMINAL, & SUBJECT TO CHANGE WITHOUT NOTICE.
 ALL DIMENSIONS ON ROTATIONAL MOLDED PARTS ARE SUBJECT TO A ± 3% TOLERANCE.

DO NOT SCALE		DRAWN BY		TITLE:	45° DRY HANDLING FLOWMASTER	REVISION
STATUS:	Released	SB		ENG. ID.		A
© SNYDER INDUSTRIES, INC., 2018				PART NO.		SHEET
<small>ALL DIMENSIONS, DESIGNS, AND INFORMATION ON THIS PRINT MUST BE CONSIDERED PROPRIETARY TO SNYDER INDUSTRIES, INC. AND MAY NOT BE USED, COPIED, OR DISTRIBUTED WITHOUT WRITTEN PERMISSION OF AN OFFICER (OR HIS AGENT) OF THE FIRM.</small>						1 OF 1
					A007199	