

OZTEC PAPER SHREDDERS

MODEL 800I PARTS LIST

ITEM	DESCRIPTION	PART #
1	PWR SWITCH	177G1
2	STOP SWITCH	177J1
3	CIRCUIT BREAKER	175A2
4	KEY LK SWITCH	177H1
5	BASE	371K1
6	FRONT PANEL	371L1
7	SIDE PANEL	371N1
8	SIDE PANEL	371M1
9	CHUTE	371RS1
10	TOP PANEL	371P1
11	REAR PANEL	371Q1

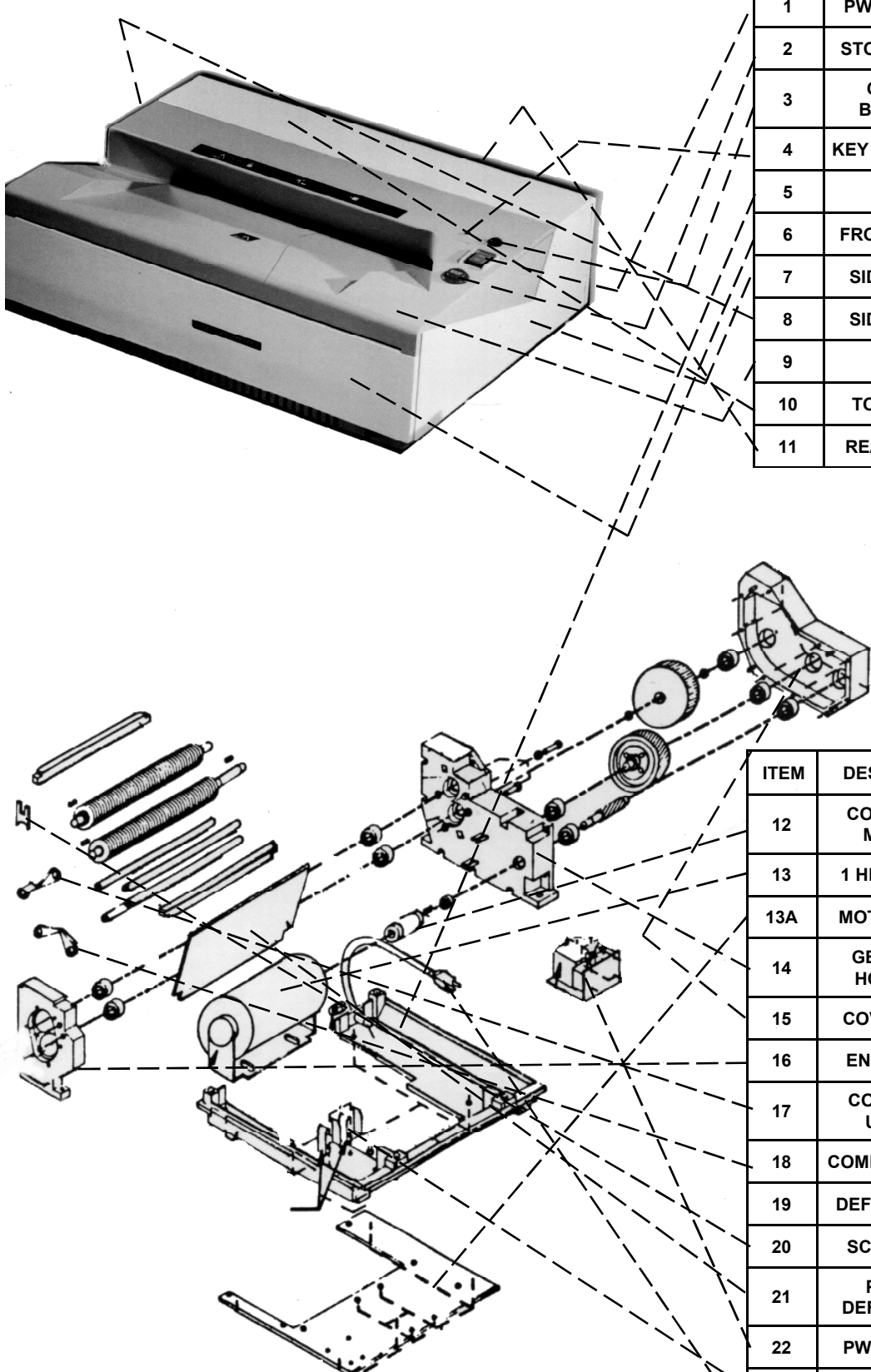

ITEM	DESCRIPTION	PART #
12	COUPLING, MOTOR	278A2
13	1 HP MOTOR	6825EA1
13A	MOTOR BASE	386BY1
14	GEARBOX HOUSING	161019
15	COVER,GBX	161020
16	END PLATE	161021
17	COMBERS, UPPER	161029
18	COMBERS,LWR	161030
19	DEFLECTORS	161028
20	SCRAPERS	436C1
21	PAPER DEFLECTOR	46M1
22	PWR RELAY	176C1
23	RELAY 2PDT	176B1
24	POWER CORD	174R1