

Fig 1 Exploded diagram of upper cover assy & hopper

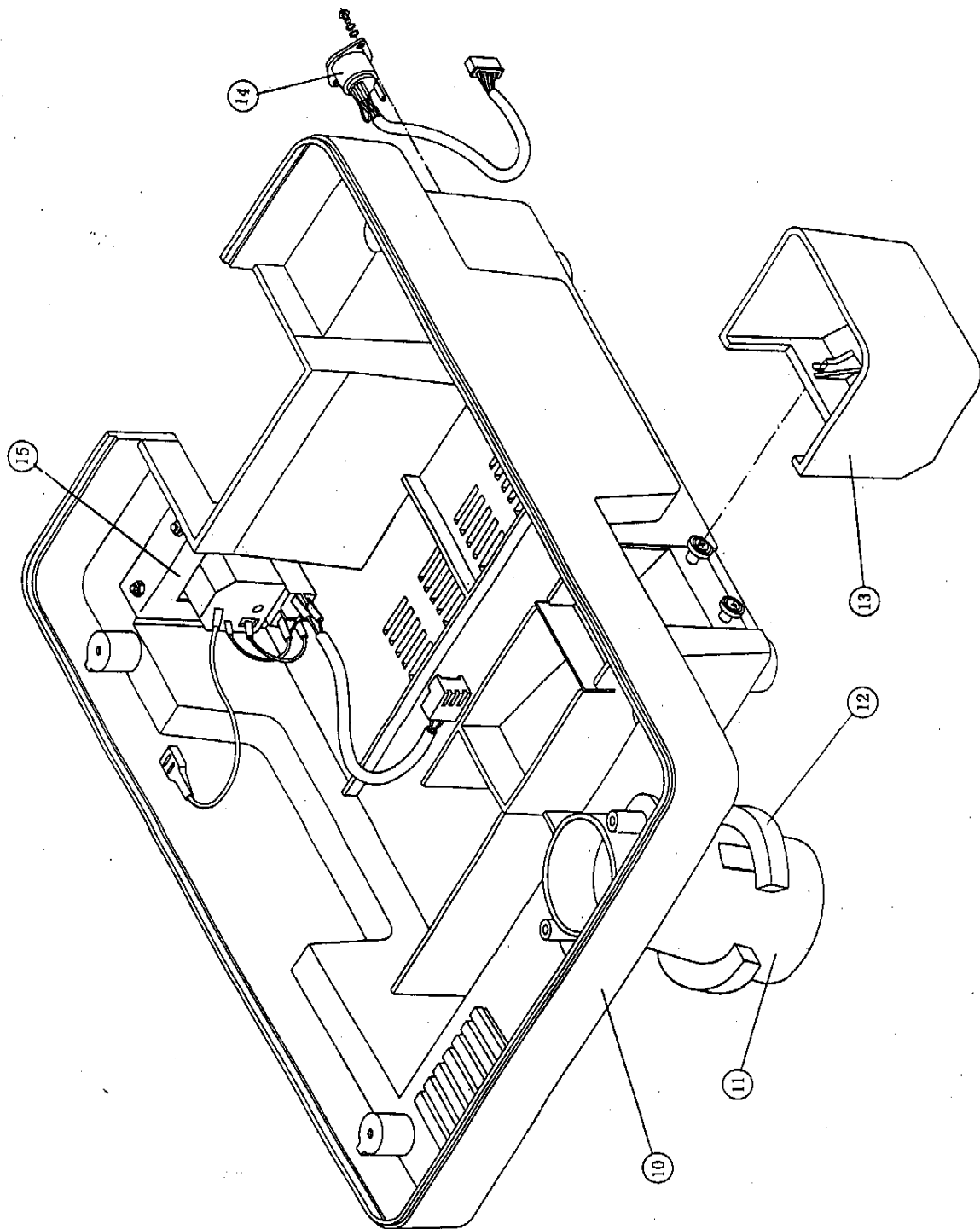

Fig. 2 Bottom cover assembly and rejected coin cup

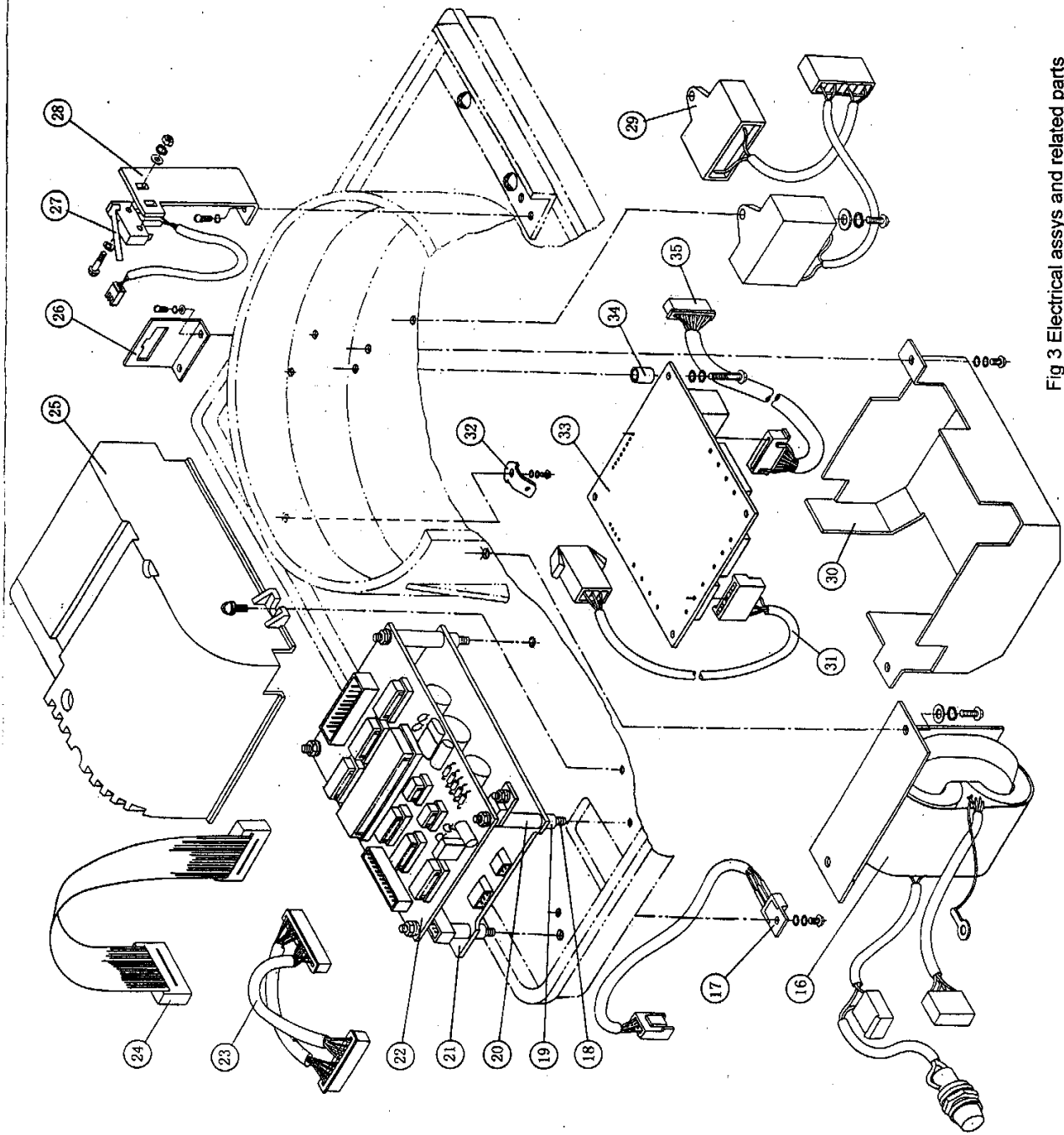

Fig 3 Electrical assys and related parts

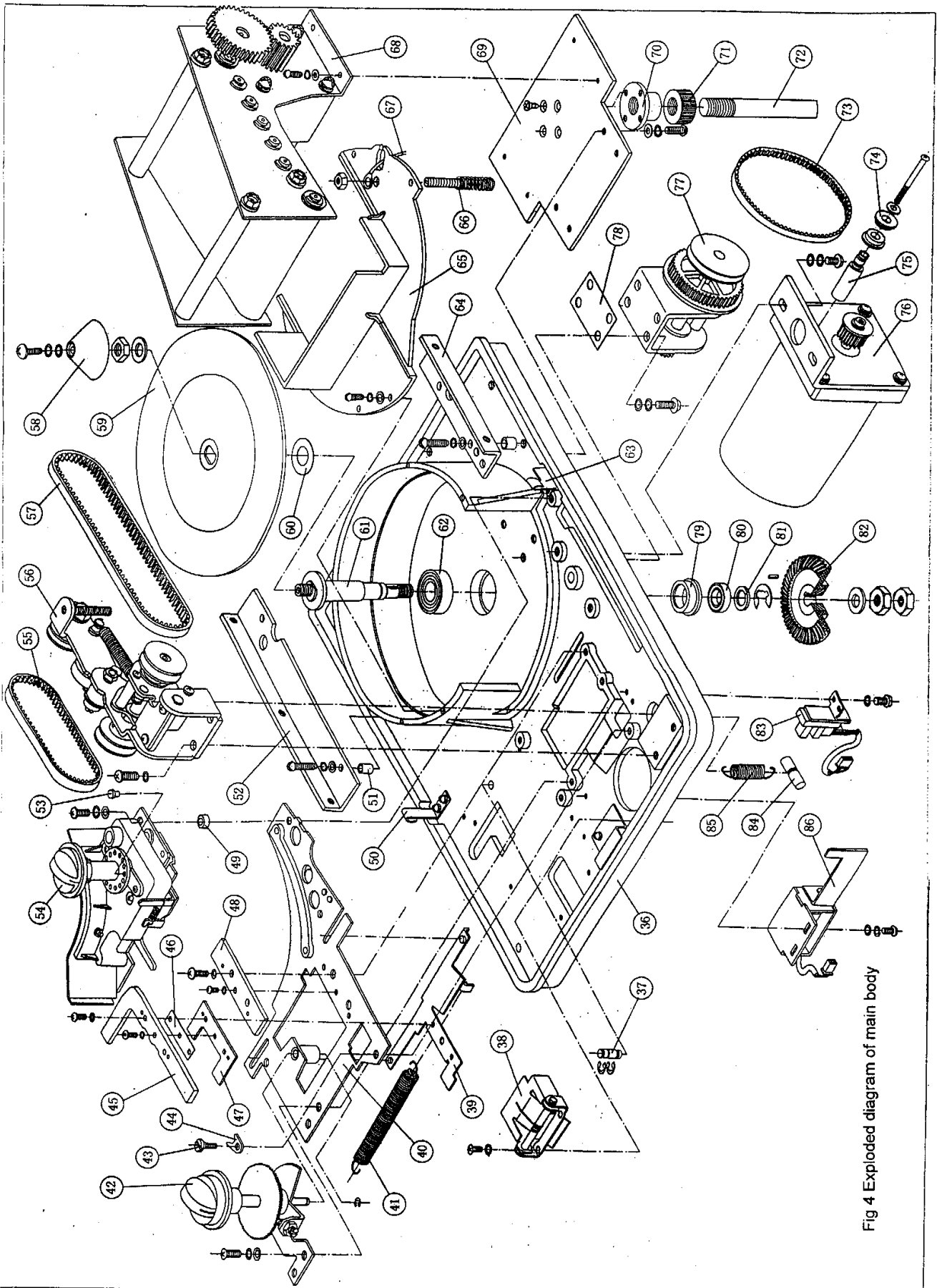

Fig 4 Exploded diagram of main body

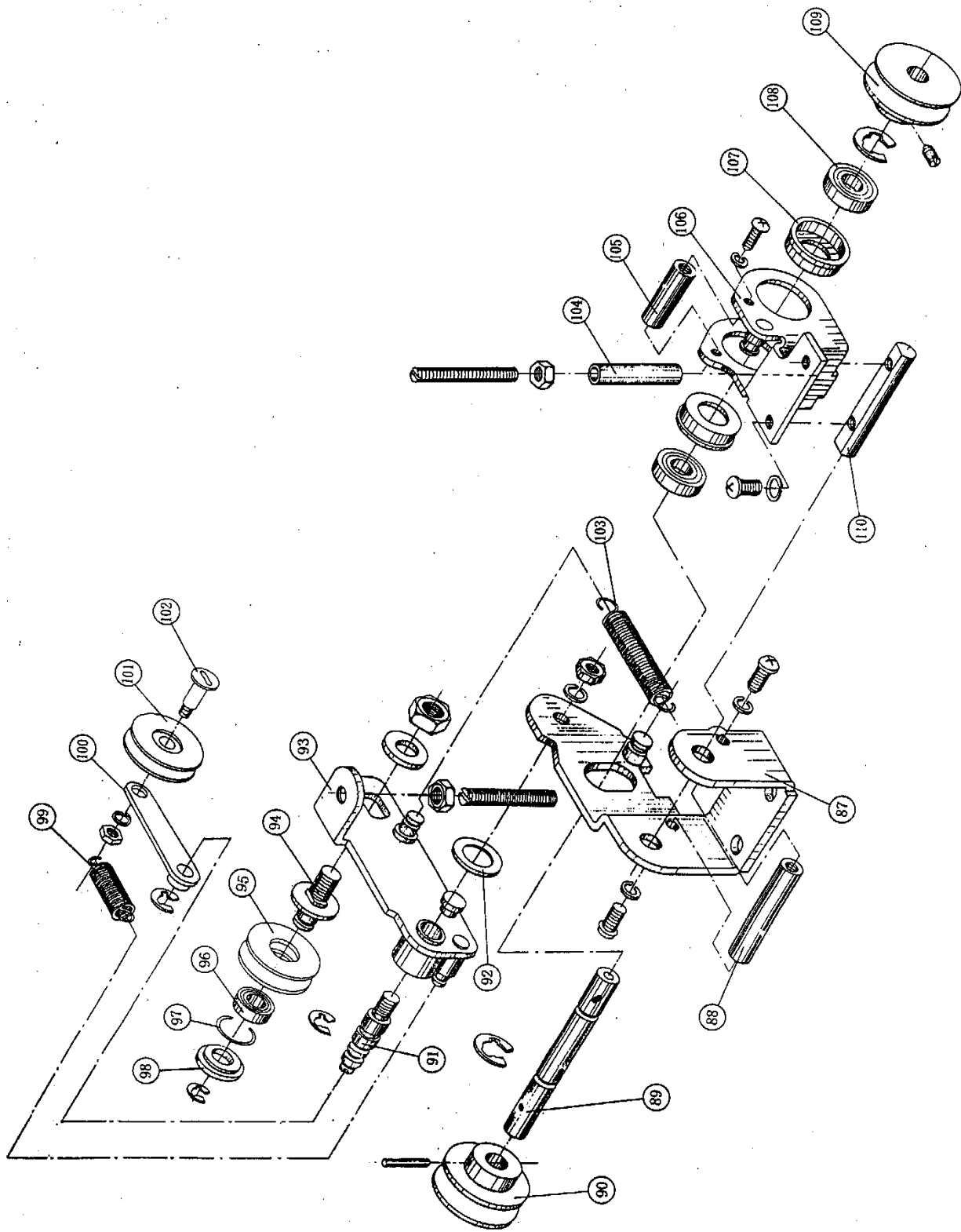

Fig.5 Exploded diagram of feed mechanism assy

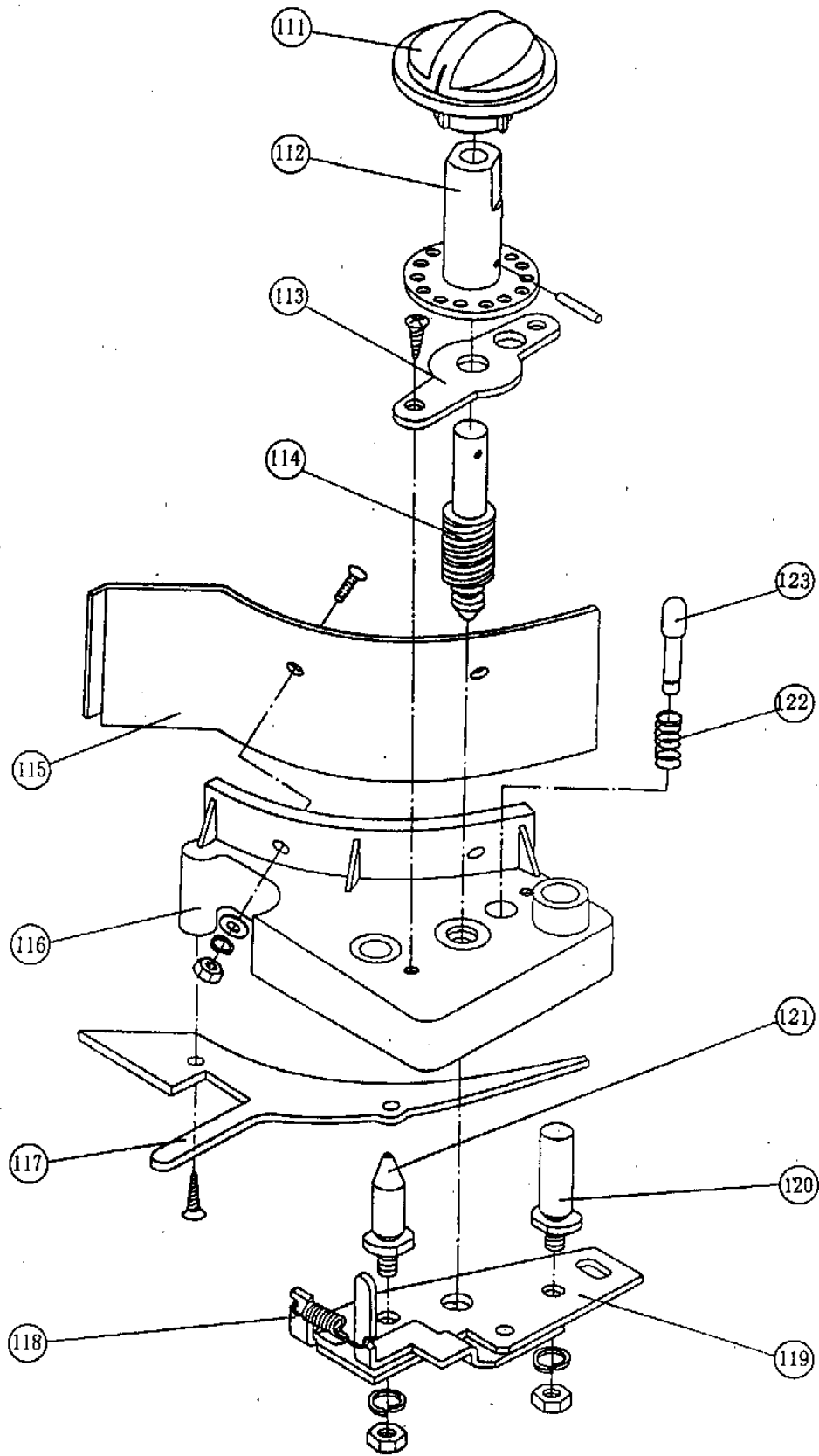

Fig.6 Exploded diagram of thickness adjustment block

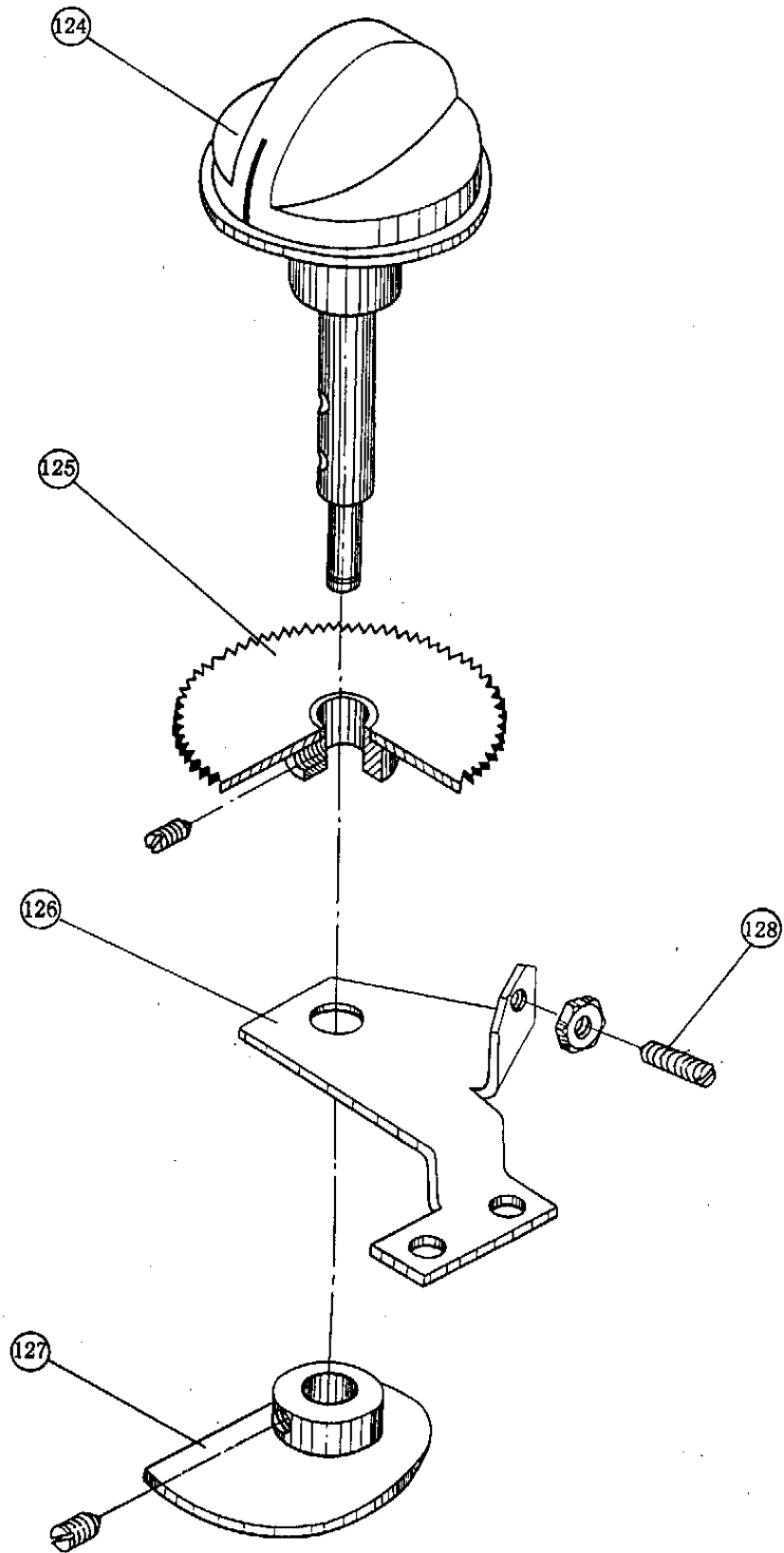

Fig.7 Exploded diagram of cam assy

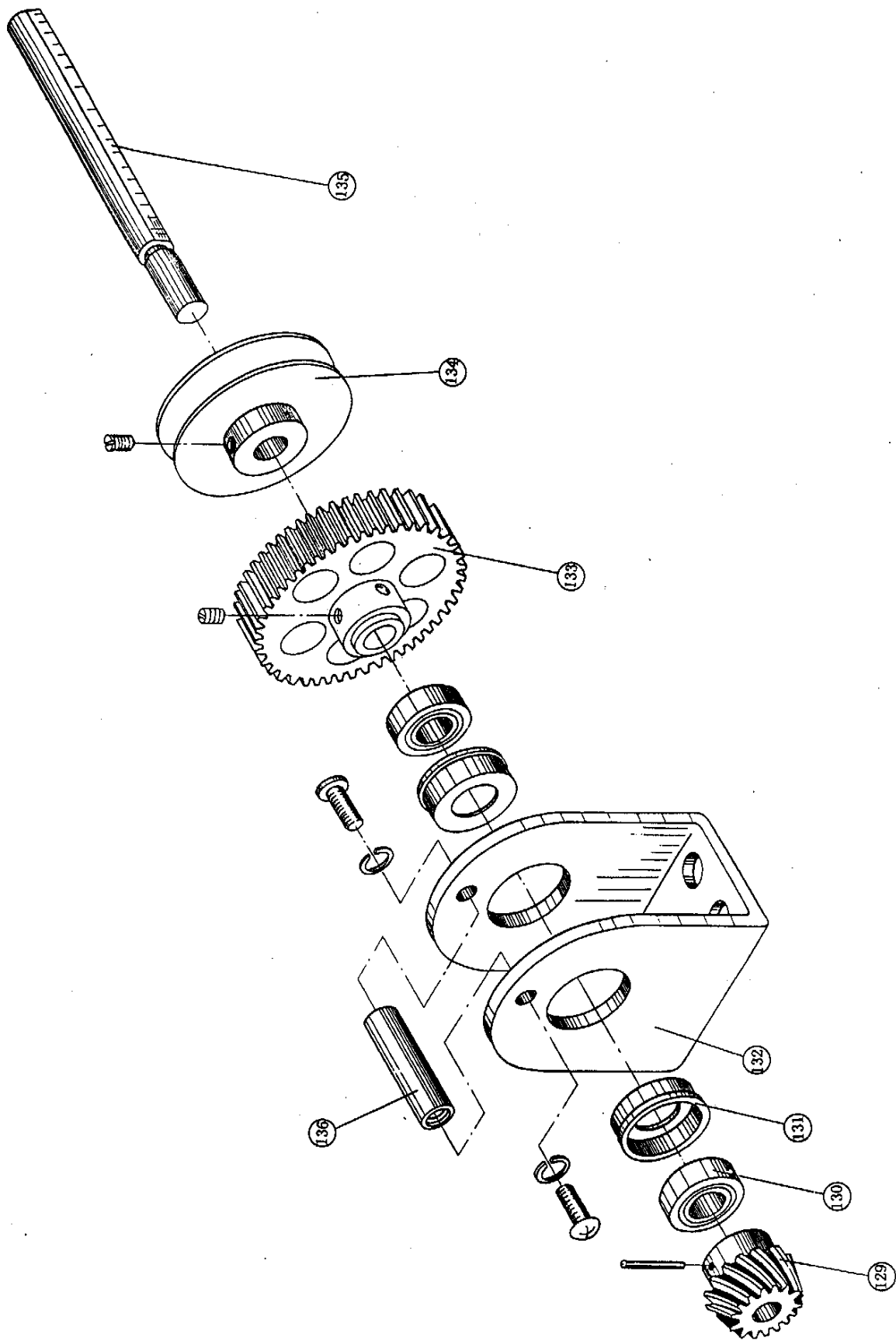

Fig.8 Exploded diagram of minor gear assembly



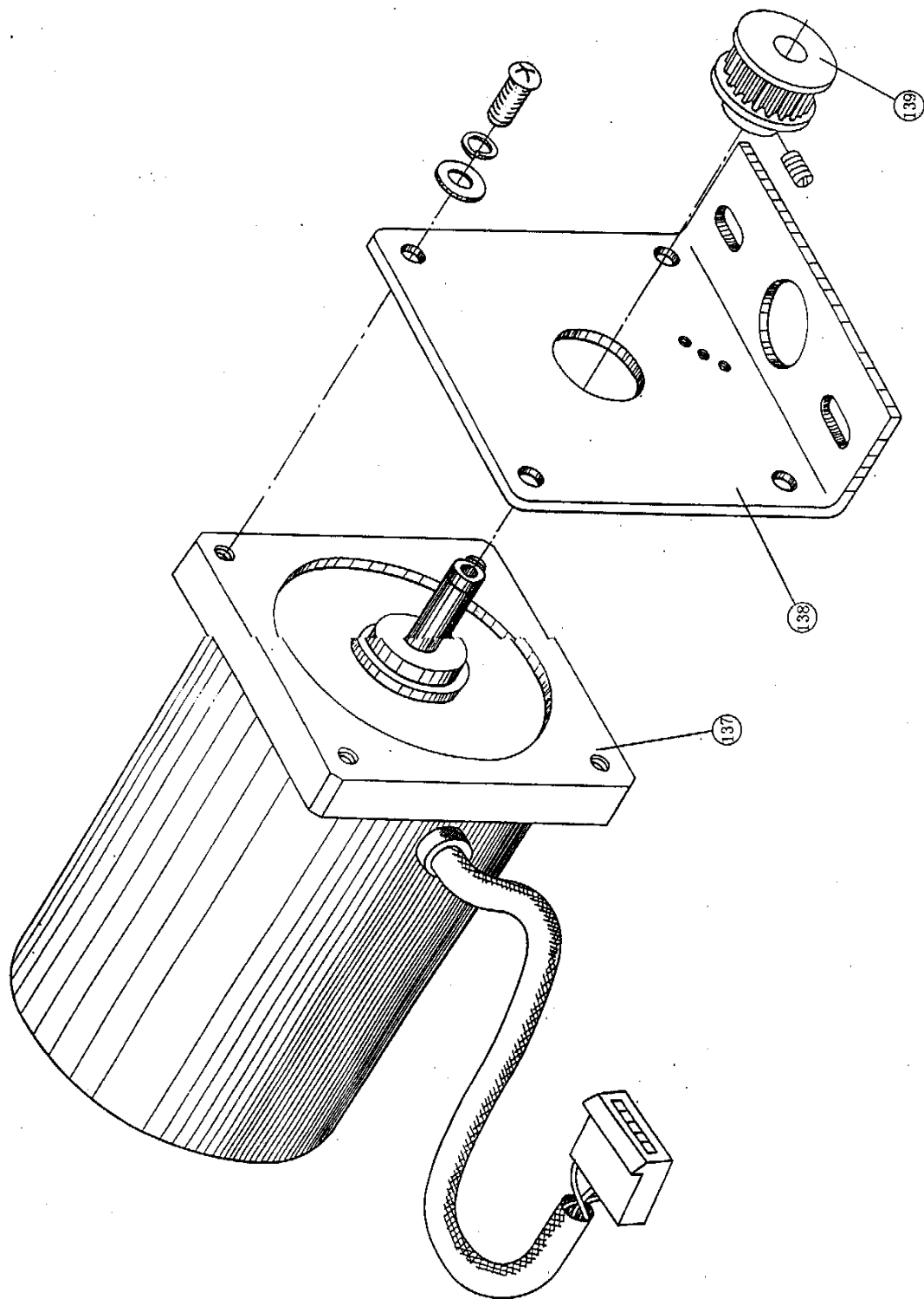

Fig.9 Exploded diagram of lower motor assembly

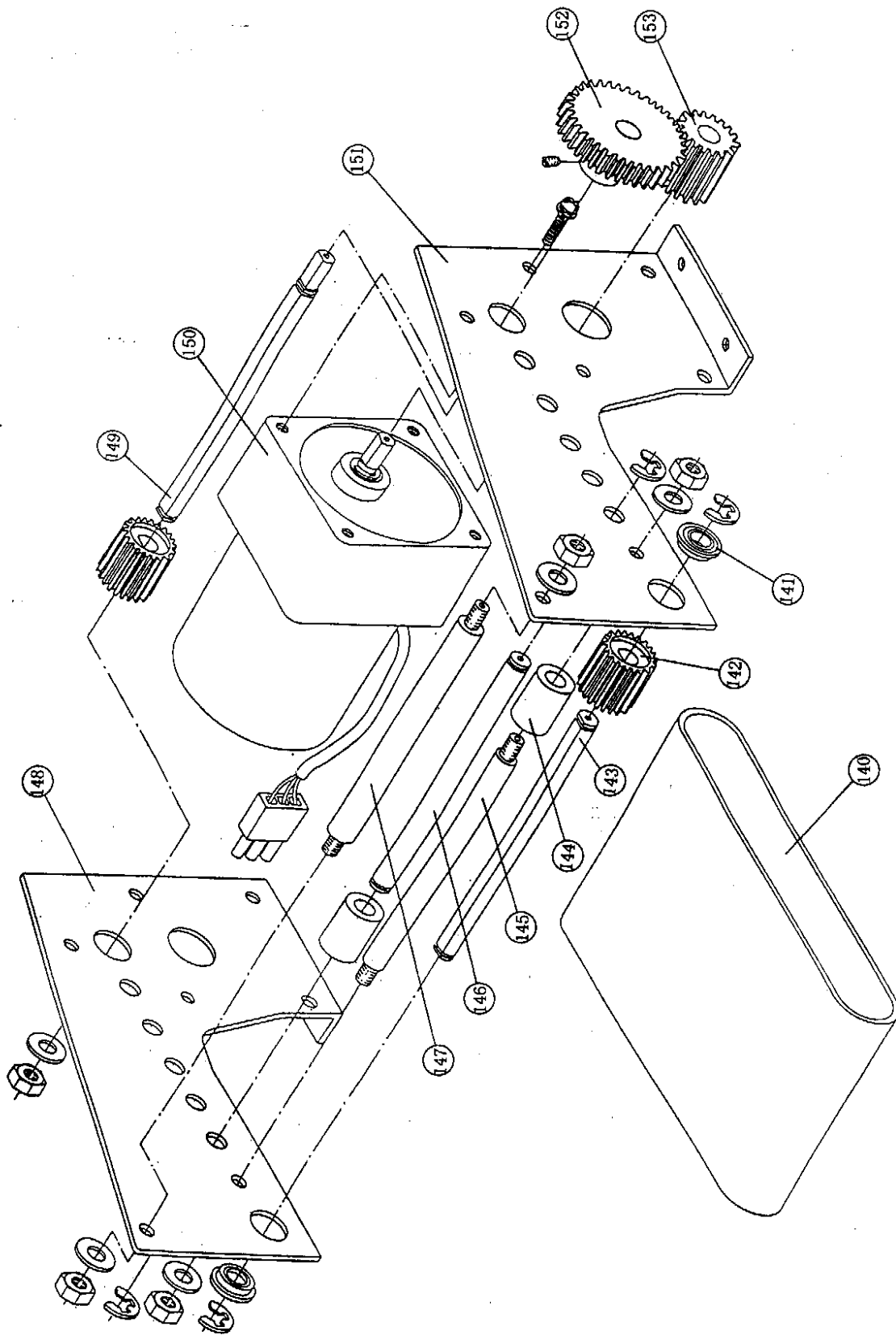

Fig.10 Exploded diagram of conveying belt assembly

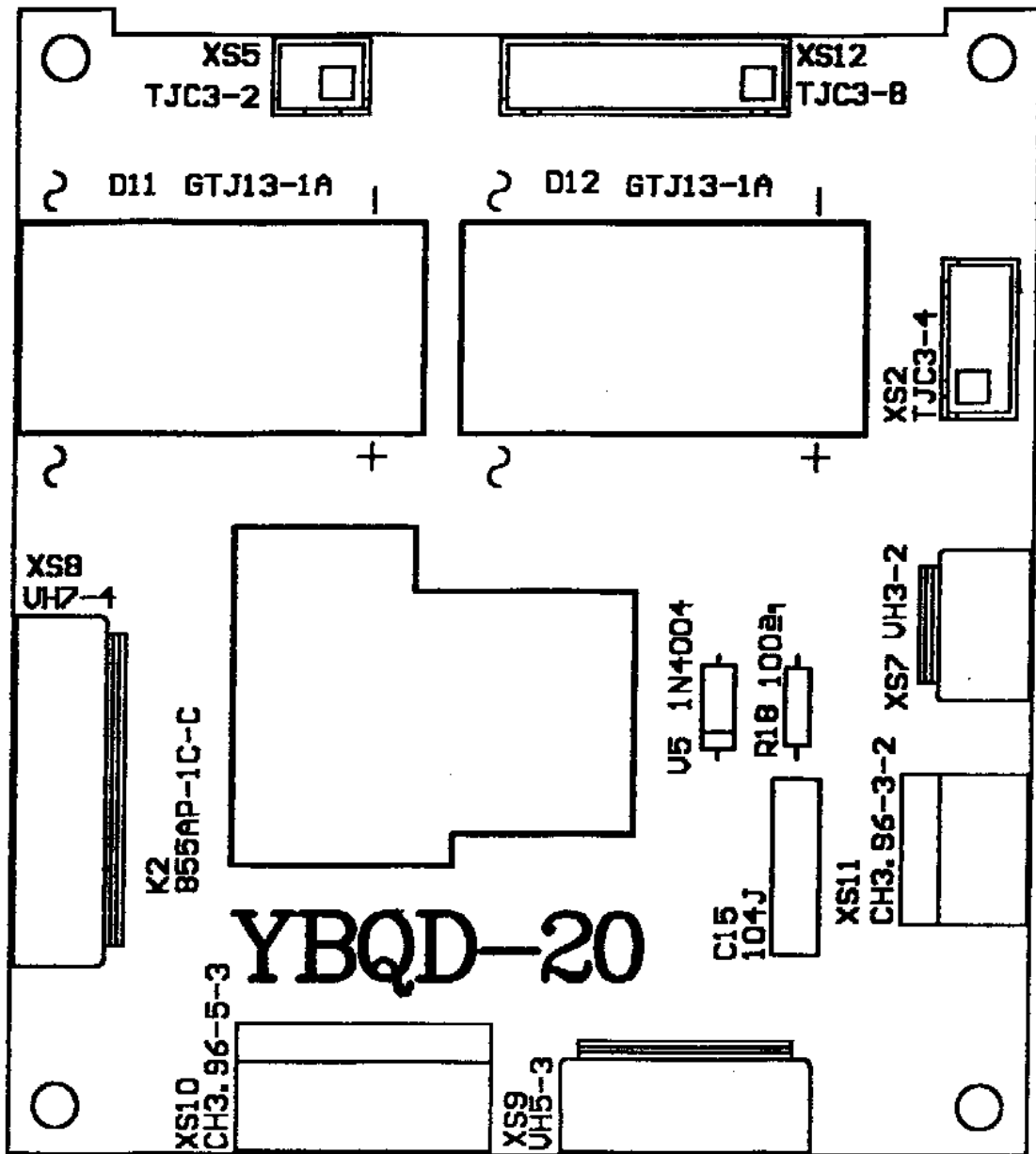

Fig.11 Component installing diagram of AC power supply board

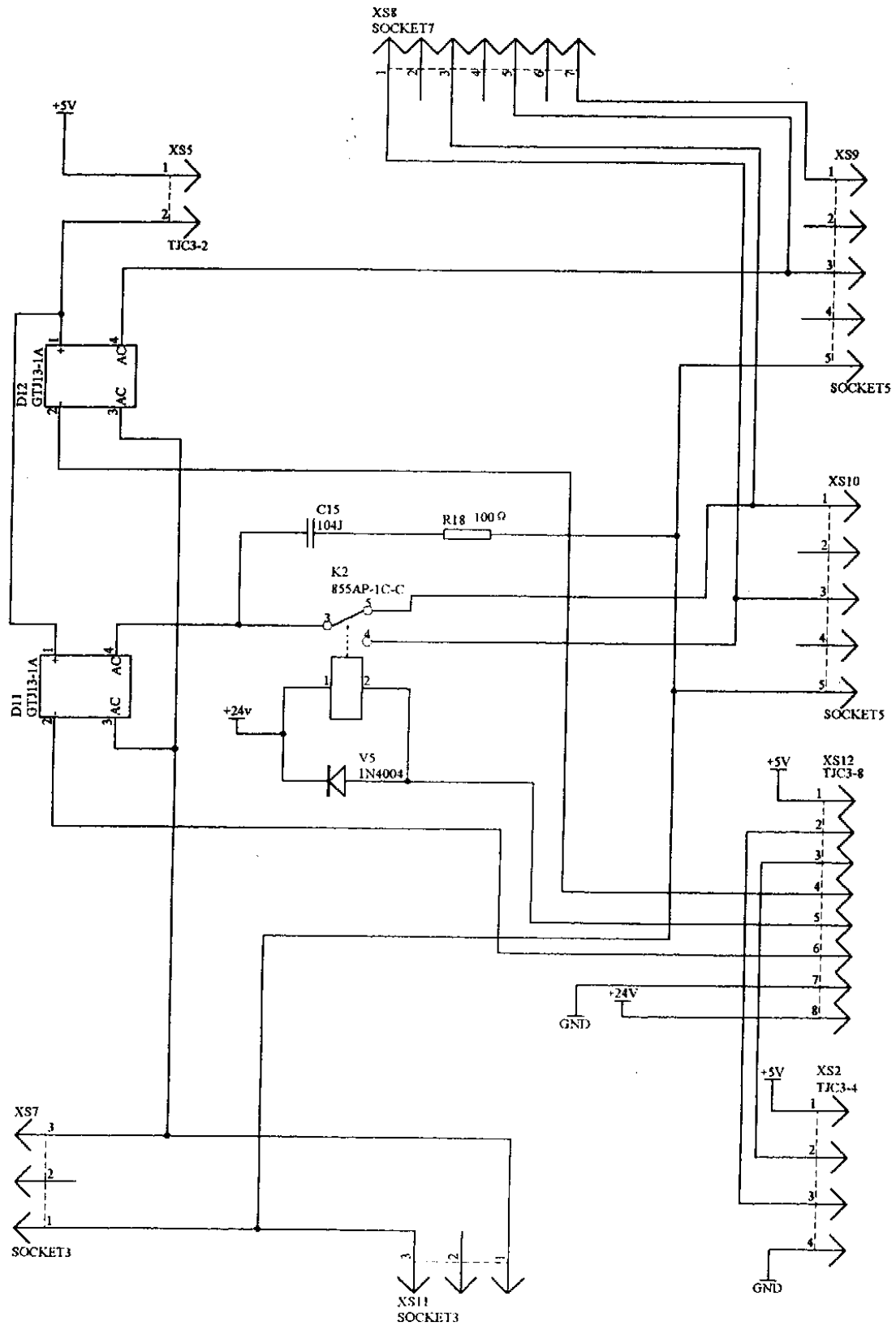

Fig.12 Electric circuit diagram of AC power supply board

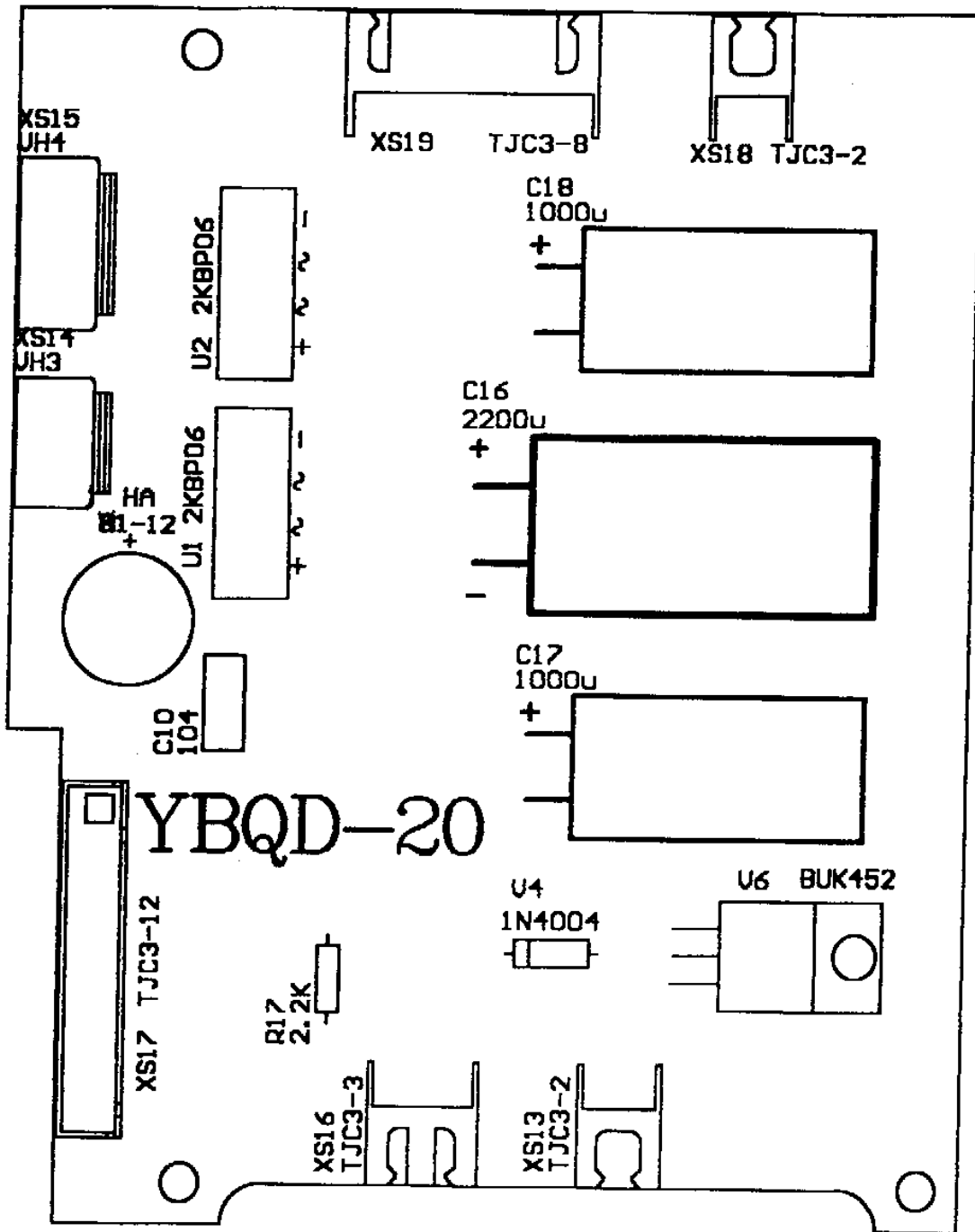

Fig.13 Component installing diagram of DC power supply board

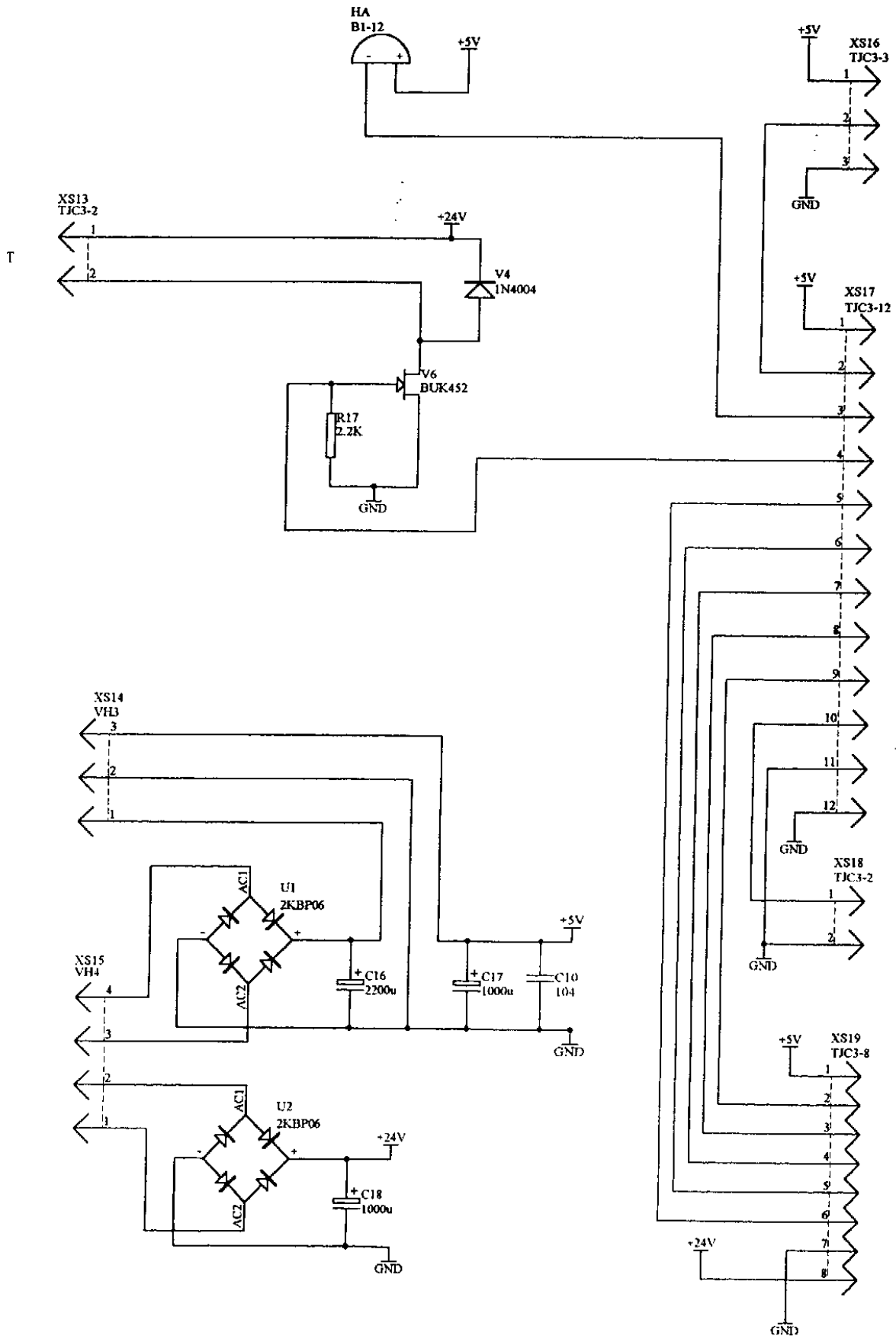

Fig.14 Electric circuit diagram of DC power supply board

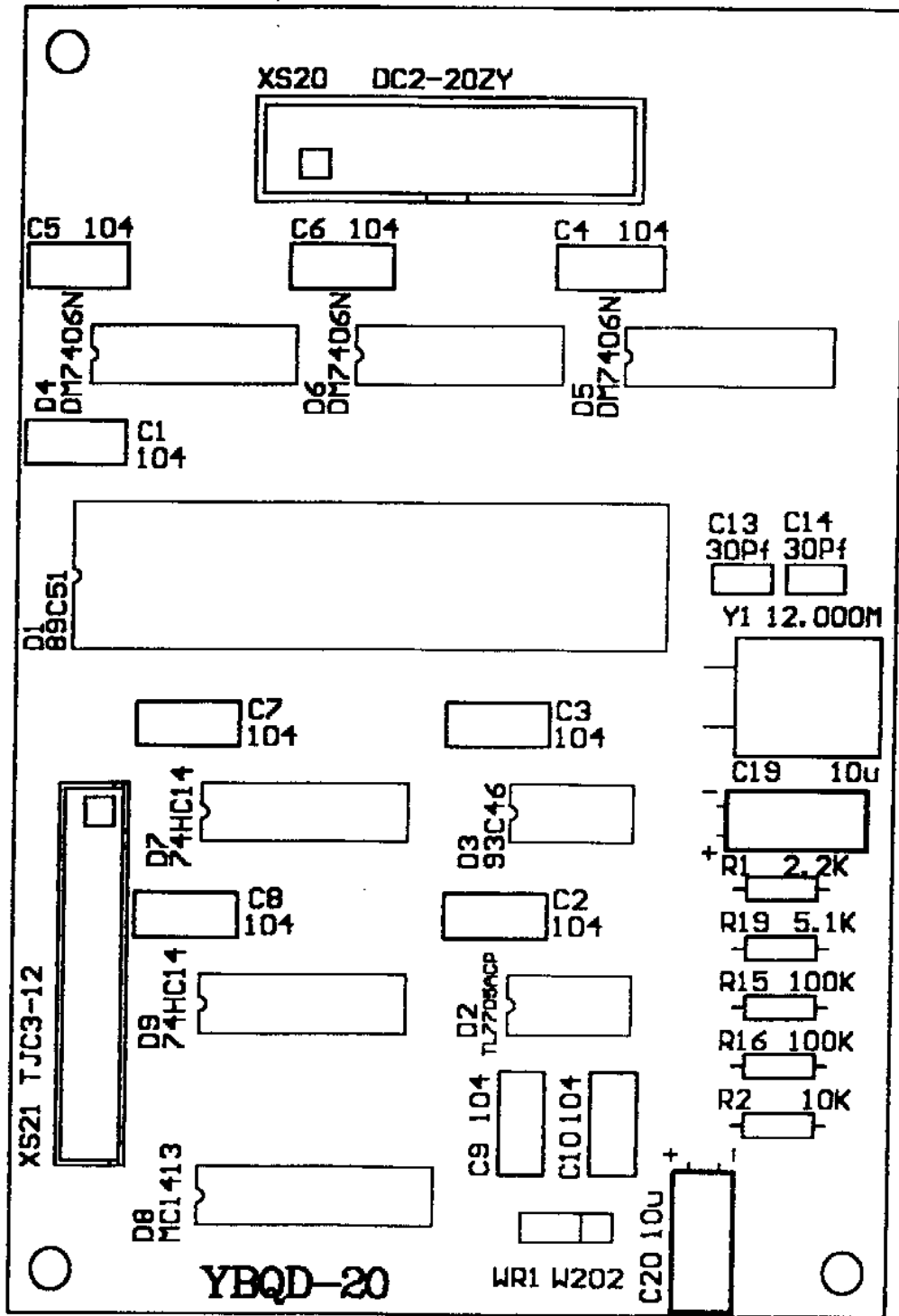

Fig.15 Component installing diagram of control board

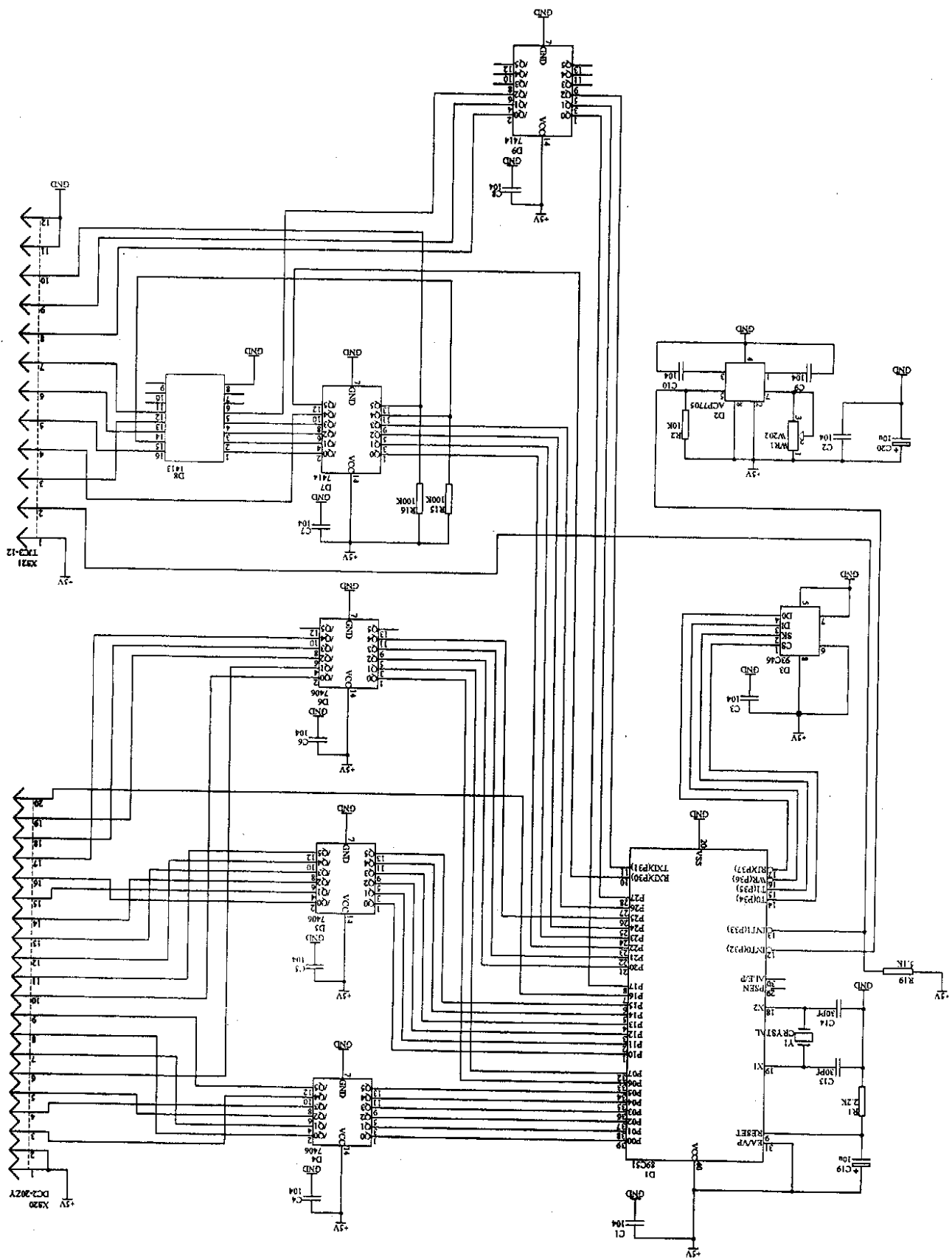
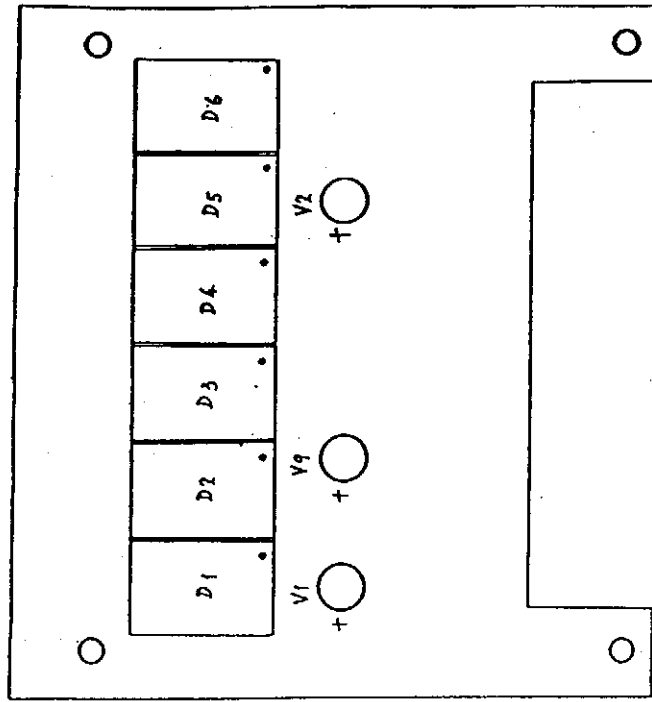
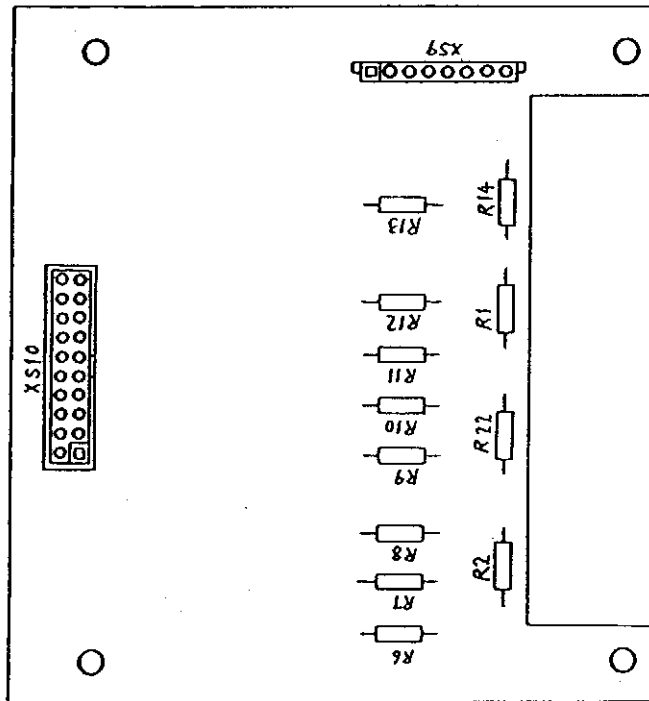

Fig.16 Electric circuit diagram of control board





B



A

Fig.17 Component installing diagram of display board

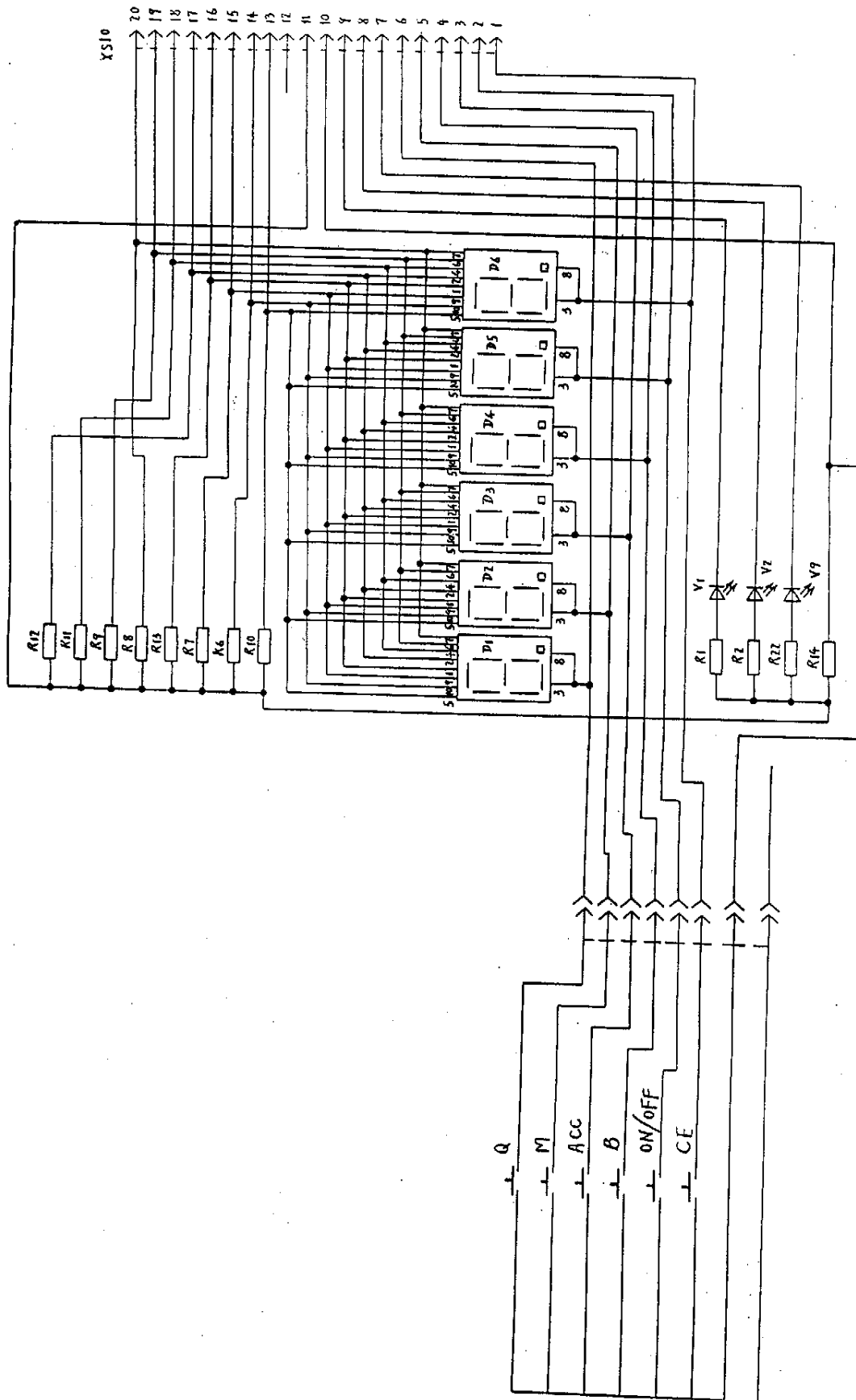
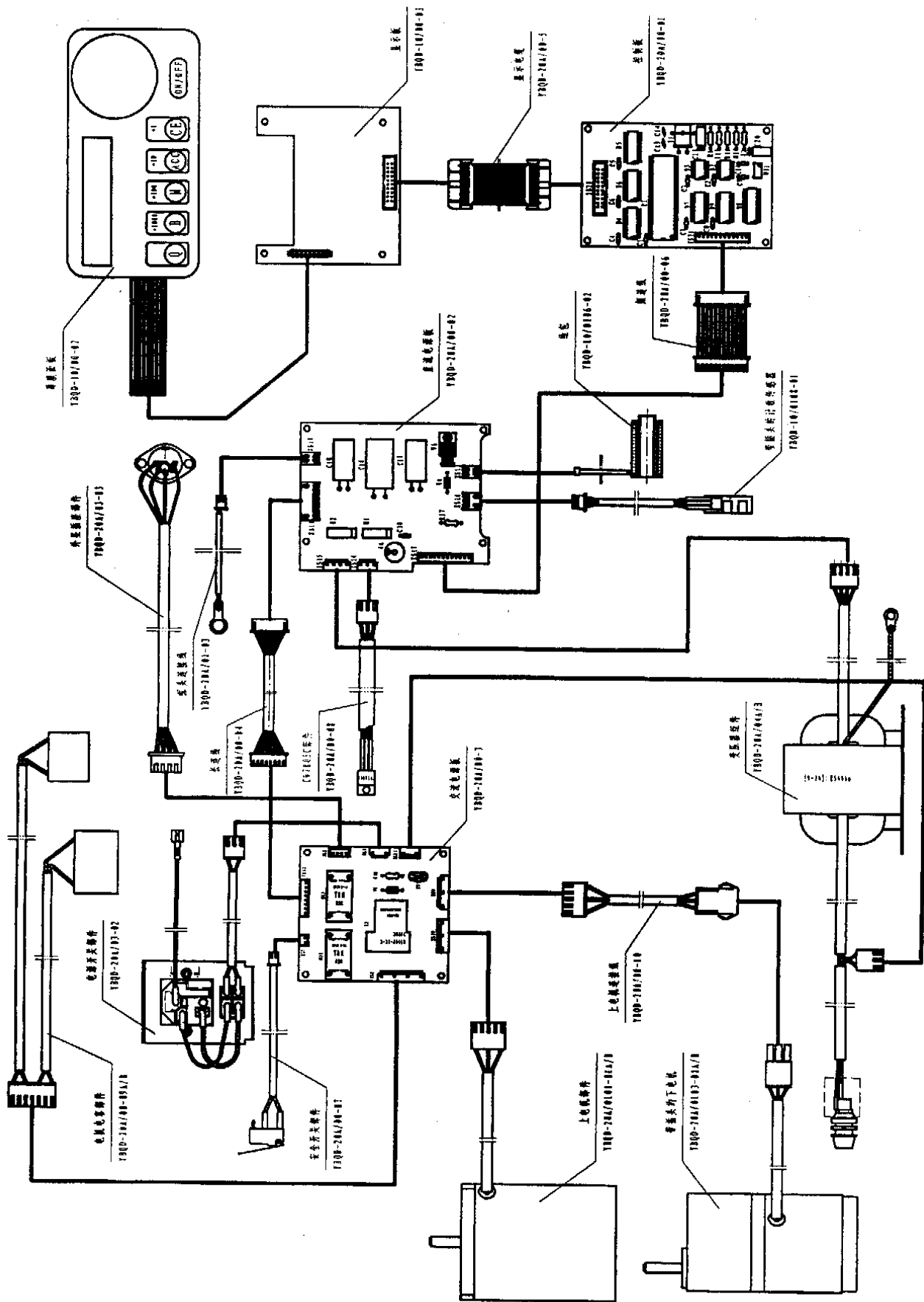

Fig.18 Electric circuit diagram of display board



g.19 Wiring diagram of the machine