

Spinnit® *EBM-S* Manual Paper Drill

**USER'S MANUAL**



***Before operating this equipment, please read these instructions completely and keep these operating instructions for future reference.***

Serial Number: \_\_\_\_\_  
Date of Purchase: \_\_\_\_\_  
Dealer: \_\_\_\_\_  
Address: \_\_\_\_\_  
\_\_\_\_\_  
Telephone Number: \_\_\_\_\_

# Table Of Contents

## 1 - Introduction

- 1.1 Your New EBM-S Paper Drill..... Page 01
- 1.2 Shipping Damage Inspection..... Page 01

## 2 - Safety

- 2.1 Safety Instructions..... Page 02
- 2.2 Warning Labels..... Page 03
- 2.3 Grounding Instructions..... Page 04

## 3 - Setting Up Your Machine

- 3.1 Loose Items Inventory..... Page 05
- 3.2 Accessories Warning..... Page 05
- 3.3 Installing the Back-gauge Assembly..... Page 06
- 3.4 Positioning the Stop Collars..... Page 06
- 3.5 Installing the Chip Bag..... Page 07
- 3.6 Electrical Instructions..... Page 07

## 4 - Operation

- 4.1 Protective Guard..... Page 08
- 4.2 Drill Bit Removal and Installation..... Page 08
- 4.3 Leveling the Drill Bits..... Page 09
- 4.4 Adjusting the Back-Gauge..... Page 09
- 4.5 Drilling Procedures..... Page 10
- 4.6 Tips on Drilling..... Page 10

## 5 - Maintenance

- 5.1 Safety..... Page 11
- 5.2 Annual Lubrication..... Page 11

## 6 - Trouble Shooting Guide

- 6.1 Determining the Cause and Correction to Certain Problems..... Page 12

## 7 - Parts Diagrams

- 7.1 Front, Rear, and Side Views..... Page 13
- 7.2 Internal Views and Table Assembly..... Page 14
- 7.3 Parts List..... Page 15

# 1 - Introduction

## 1.1 - Your New EBM-S Paper Drill

- Thank you for your purchase of the Spinnit®EBM-S Paper Drill.
- We ask that you take a moment to fill in the serial number and other information on the front cover of the manual. Please keep this manual as a reference for future use.
- For parts and service, please contact the Lassco-Wizer Dealer from whom you purchased the machine. If you require assistance in locating a Lassco-Wizer Dealer please contact our customer service department at 585-436-1934. Please have the model of your machine and the serial number when you call.
- If you wish to write to us, send correspondence to:

Lassco-Wizer  
Attn: Customer Service  
485 Hague Street  
Rochester, NY 14606

## 1.2 - Shipping Damage Inspection

- Remove the machine from the carton and inspect for any shipping damage. If any damage is present, report the damage to the carrier immediately; failure to do so may void any warranties.

## 2 - Safety

### 2.1 - Safety Instructions

- All operators must read and understand the Users Manual including all safety instructions before using this equipment. Failure to fully understand the safety instructions can result in personal injury. If after reading the manual you are still uncertain about use, please contact the dealer from whom you purchased the machine for assistance. If you need contact information for a Service Technician nearest you please call 585-436-1934.
- SAFETY OF THIS EQUIPMENT IS THE RESPONSIBILITY OF THE USER(S).
- Please read and follow all warning labels on your machine.
- INDUSTRIAL AND IN-PLANT USE ONLY. This equipment is for use in industrial and in-plant areas only and must be operated by trained and qualified personnel.
- WEAR PROPER APPAREL. Do not wear loose clothing, gloves, neckties, rings, bracelets, or other jewelry which may get caught in moving parts. Non slip footwear is recommended. Wear protective hair covering to contain long hair.
- Keep hands clear while operating machine.
- ALWAYS USE SAFETY GLASSES. Also use face or dust mask if drilling operation is dusty. Everyday eyeglasses only have impact resistant lenses, they are NOT safety glasses.
- KEEP GUARDS IN PLACE and in working order.
- Always disconnect the power before servicing this machine. Service should only be performed by a QUALIFIED TECHNICIAN.
- Always turn the machine to off mode and wait for the drills to stop spinning before installing or removing drill bits. Keep hands away from drills when operating. PLEASE NOTE THAT THE DRILL BITS MAY BE HOT AFTER USE. PROCEED WITH CAUTION WHEN CHANGING THE DRILL BITS.
- DON'T USE IN DANGEROUS ENVIRONMENT. Don't use this machine in damp or wet locations, or expose it to rain. Keep work area well lighted.
- THIS MACHINE IS DESIGNED FOR ONE PERSON OPERATION. Never operate the machine with more than one person.

- KEEP CHILDREN AWAY. All visitors should be kept a safe distance from the work area.
- MAKE WORKSHOP KID-PROOF with padlocks or master switches.
- DON'T FORCE MACHINE. It will do the job better and safer at the rate for which it was designed.
- USE RIGHT MACHINE. Don't force tool or attachment to do a job for which it was not designed.
- MAINTAIN MACHINE WITH CARE. Keep tools sharp and clean for best and safest performance. Follow instructions for lubricating and changing accessories.
- REMOVE ADJUSTING KEYS AND WRENCHES. Form habit of checking to see that keys and adjusting wrenches are removed from machine before turning it on.
- KEEP WORK AREA CLEAN. Cluttered areas and benches invite accidents.
- DISCONNECT MACHINE before servicing; when changing accessories, such as drill bits, drill blocks, and the like.
- REDUCE THE RISK OF UNINTENTIONAL STARTING. Make sure the power switch is in the off position before plugging in.
- USE RECOMMENDED ACCESSORIES. Consult the user's manual for recommended accessories. The use of improper accessories may cause risk of injury to persons.
- NEVER STAND ON MACHINE. Serious injury could occur if the machine is tipped.
- DON'T OVERREACH. Keep proper footing and balance at all times.
- CHECK DAMAGED PARTS. Before further use of the machine, a guard or other part that is damaged should be carefully checked to determine that it will operate properly and perform its intended function--check for alignment of moving parts, binding of moving parts, breakage of parts, mounting, and any other conditions that may affect its operation. A guard or other part that is damaged should be properly repair or replaced.
- NEVER LEAVE MACHINE RUNNING UNATTENDED. TURN POWER OFF. Don't leave machine until it comes to a complete stop.

# 2 - Safety

## 2.2 - Warning Labels

### English



- WARNING: DO NOT EXPOSE TO RAIN OR USE IN DAMP LOCATIONS.

	<b>⚠ WARNING</b>
	Read and understand operator's manual and all other safety instructions before using this equipment

<b>⚠ WARNING</b>
FOR INDUSTRIAL AND IN-PLANT USE ONLY.

	<b>⚠ WARNING</b>
	Entanglement hazard. Rotating parts. Do NOT operate with exposed long hair, jewelry or loose clothing.

	<b>⚠ WARNING</b>
	Risk of eye injury. Wear eye protection.

	<b>⚠ WARNING</b>
	Risk of Injury. Do NOT operate without guards in place.

	<b>⚠ WARNING</b>
	Drill bits may be hot after use. Allow drill bits to cool down before touching

	<b>⚠ DANGER</b>	
	<b>Severe shock hazard.</b> Only authorized personnel may service this equipment. Turn power OFF before entry.	

### French

- AVERTISSEMENT: NE PAS EXPOSER À LA PLUIE ET NE PAS UTILISER DANS LES EMPLACEMENTS HUMIDES

<b>⚠ AVERTISSEMENT</b>
Lire et bien comprende le manuel de l'opérateur avant d'utiliser cette machine. Le fait de ne pas suivre les consignes d'utilisation peut entraîner des blessures graves ou endommager l'équipement.

<b>⚠ AVERTISSEMENT</b>
POUR UTILISATION INDUSTRIELLE ET EN USINE SEULEMENT.

<b>⚠ AVERTISSEMENT</b>
Risque d'enchevêtrement. Pièces rotatives. Ne portez jamais de vêtements amples ou de bijoux et attachez-vous les cheveux lorsque vous opérez cette machine.

<b>⚠ AVERTISSEMENT</b>
Risque de blessures aux yeux. Protection des yeux nécessaire.

<b>⚠ AVERTISSEMENT</b>
Faire attention de ne pas se blesser. Ne pas utiliser cette machine sans la présence de tous les dispositifs de sécurité.

<b>⚠ AVERTISSEMENT</b>
Les outils de forage peuvent chauffer à l'usage. Laisser refroidir les outils de forage avant de les toucher.

<b>⚠ DANGER</b>
Grave risqué d'électrocution. Seul le personnel autorisé peut faire l'entretien de cet équipement. COUPEZ l'alimentation électrique avant d'entrer.

## 2.3 - Grounding Instructions

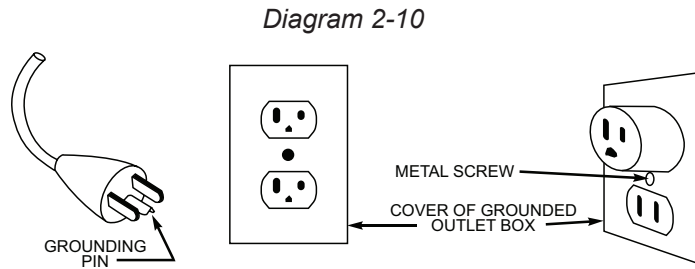

- In the event of a malfunction or breakdown, grounding provides a path of least resistance for electric current to reduce the risk of electric shock. This tool is equipped with an electric cord having an equipment-grounding conductor and a grounding plug. The plug must be plugged into a matching outlet that is properly installed and grounded in accordance with all local codes and ordinances.
- **DO NOT MODIFY THE PLUG PROVIDED.** If it will not fit the outlet, have the proper outlet installed by a **QUALIFIED ELECTRICIAN**.
- Improper connection of the equipment-grounding conductor can result in a risk of electric shock. The conductor with insulation having an outer surface that is green with or without yellow stripes is the equipment-grounding conductor. If repair or replacement of the electric cord or plug is necessary, do not connect the equipment-grounding conductor to a live terminal. Check with a **QUALIFIED ELECTRICIAN** or service personnel if the grounding instructions are not completely understood, or if in doubt as to whether the tool is properly grounded. Use only 3-wire extension cords that have 3-prong grounding plugs and 3-pole receptacles that accept the machine's plug.
- This machine is intended for use on a circuit that has an outlet that looks like the one illustrated in diagram 2-10. The machine has a grounding plug that looks like the plug illustrated in diagram 2-10. Make sure the machine is connected to an outlet having the same configuration as the plug. No adapter is available or should be used with this machine. If the machine must be reconnected for use on a different type of electric circuit, the reconnection should be made by qualified service personnel; and after reconnection, the tool should comply with all local codes and ordinances.

# 3 - Setting Up Your Machine

## 3.1 - Loose Items Inventory

- Please remove and inspect the following items:

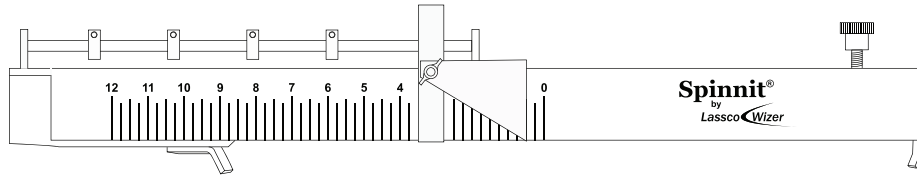

EBMS-115A: Back-gauge Assembly

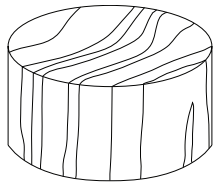

EBM-10: Drill Block (1)



DRILL-EASE: Drill Bit Lubricant (1)



EBM2-1048: Chip Bag (1)



SPIN-EZE: Drill Bit Lubricant (1)



Hollow Drill Bit (1)  
(these items may be installed)

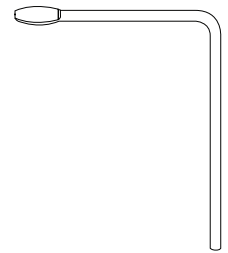

EBM-32: Chuck Release Key (1)



HEX-18: Hex Wrench  
1/8" (1)



HEX-332: Hex Wrench  
3/32" (1)

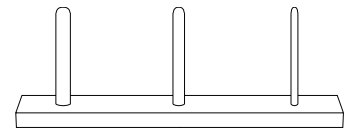

CC-2: Chip Clearer (1)

## 3.2 - Accessories Warning

- **USE RECOMMENDED ACCESSORIES.** Only use accessories approved by a Lassco-Wizer. The use of improper accessories may cause risk of injury to persons.

## 3 - Setting Up Your Machine

### 3.3 - Installing the Back-gauge Assembly

- 3.3.1** Attach the Backgauge (EBMS-115A) to the Table by hooking the left end over the Side Iron (FM4-4003) on the side as shown in the accompanying pictures. Align both ends of the backgauge using the Table Scales so that it is squared correctly. When it is positioned as desired, tighten down the Backgauge Clamp (EBMS-10).
- 3.3.2** Do not position the Backgauge too close to the hollow drill bit so that it touches. This can cause serious damage to the hollow drill bit causing it to break or shatter. The Backgauge must be at least 1/8" from the circumference of the hollow drill bit

Diagram 3-10

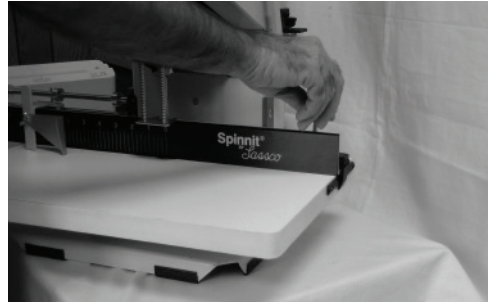
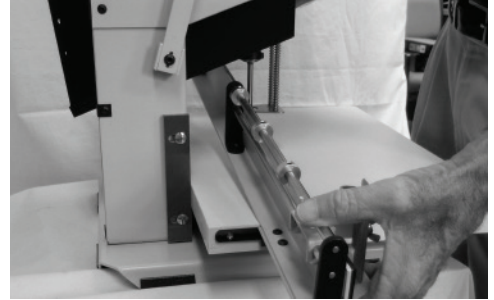

### 3.4 - Positioning the Stop Collars

- 3.4.1** For multi hole drilling, adjust the Stop Collars (EBM-47) by loosening them with the provided Hex Wrench (HEX-332). Slide the Stop Collars (EBM-47) to the desired positions and tighten. Slide the Paper Side Stop (EBMS-8001) against the Stop Collars to brace it in place. When its time to drill slide the product up against the Paper Side Stop and hold in place.
- 3.4.2** To slide the Paper Side Stop to the next Stop Collar, lift up on the Paper Side Stop releasing the bracing pin from hitting the Stop Collar as shown. Slide the Paper Side Stop past the Stop Collar and set it down so that it braces against the next Stop Collar.

Diagram 3-20

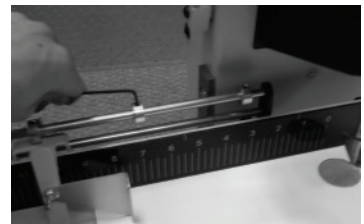
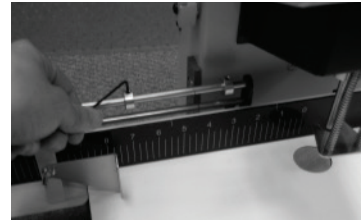

Diagram 3-30



## 3 - Setting Up Your Machine

### 3.5 - Installing the Chip Bag

- 3.5.1** Attach the chip bag as shown by stretching the open end over the top hook of the chip chute. Continue fitting it around the entire edge of the chip chute making sure it is snug.
- 3.5.2** Be sure to empty the chip bag regularly as needed. Failure to empty the chip bag can result in clogging of the chip chute.

Diagram 3-40



### 3.6 - Electrical Instructions

- 3.6.1** Your EBM-S comes with an electrical cord containing the plug to fit into a standard grounded 115V outlet. This machine has a full load draw of 5.5 Amps.
- 3.6.2** Making sure that nothing is interfering with the drill bits, plug the cord set into a grounded 115V outlet. To turn the machine on, press the Rocker Switch on the front of the shroud.

Diagram 3-50

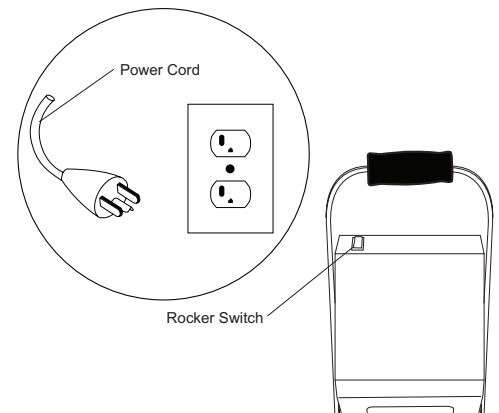



## 4 - Operation

### 4.1 - Protective Guard

- 4.1.1** Your EBM-S comes with a protective guard installed. DO NOT operate this machine without the guard in place.
- 4.1.2** Please note that when you are performing certain operations such as removing and installing drill bits, you will need to move the guard out of the way. Making sure the power to the machine is disconnected or locked-out, push the guard up and hold in place while performing necessary operations or maintenance. The protective guard should not be removed during operation.

Diagram 4-10

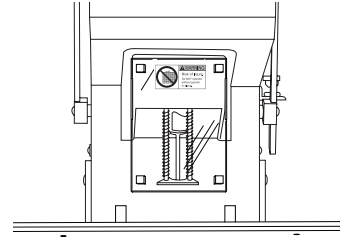

### 4.2 - Drill Bit Removal and Installation



**CAUTION: DRILL BITS MAY BE HOT AFTER USE. ALLOW DRILL BITS TO COOL DOWN BEFORE TOUCHING.**



**BEFORE REMOVING OR INSTALLING THE DRILL BITS, DISCONNECT OR LOCK-OUT THE POWER SUPPLY.**

- 4.2.1** We recommend using a piece of card stock on the Table when leveling the drill bit to avoid drilling into the drill strip. This will lengthen the life of your drill bits and keep them sharper.
- 4.2.2** Remove the hole guard which is attached to the chuck. This is done by grasping the bent end and sliding the guard off.
- 4.2.3** Using the Chuck Release Key (EBM-32), insert the tapered end facing down into the chuck hole. With a clockwise motion turn the Chuck Release Key 45 degrees. The drill bit will slide out of the chuck. It is recommended that you hold onto the drill bit so that it does not drop out of the chuck damaging the tip.
- 4.2.4** To install a drill bit, grasp the drill bit, and being careful to keep it straight, press it up into the chuck.
- 4.2.5** Seat the drill bit by using a stack of scrap paper. Set the scrap on the table. Step on the foot pedal slowly raising the table toward the Drill Bit. Put light pressure on the hollow Drill Bit seating it firmly in place.
- 4.2.6** Remove the scrap paper and turn the machine on to check the concentricity of the bit. If the bit is not concentric, remove it and repeat steps 4.2.2 through 4.2.5 until it is concentric.
- 4.2.7** When the drill bit is correctly installed replace the hole guard back onto the chuck to protect debris from clogging the chuck.

Diagram 4-20

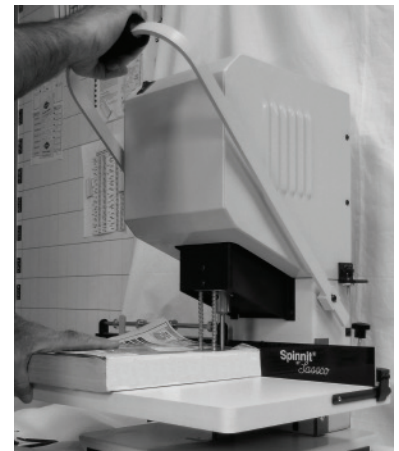
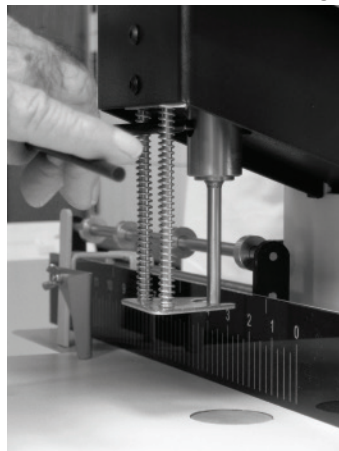

## 4 - Operation

### 4.3 - Leveling the Drill Bits

- 4.3.1** We recommend using a piece of card stock on the Table when leveling the drill bits to avoid drilling into the drill strip. This will lengthen the life of your drill bits and keep them sharper.
- 4.3.2** To level the drill bit to the Table follow steps 4.3.3 through 4.3.5.
- 4.3.3** Loosen the Leveling Knob on the right hand side of the machine.
- 4.3.4** Pull down on the Handle to raise the Table until the hollow drill bit is just touching the Drill Strip (EBM2-1034).
- 4.3.5** Hold the Handle in place and tighten down the Leveling Knob until it hits the Handle Bracket. This will stop the Handle from being pulled down too far.
- 4.3.6** It is important to always level the drill bit before each use and after sharpening. This will make sure you don't drill into the Drill Strip--dulling the hollow drill bit.

Diagram 4-30

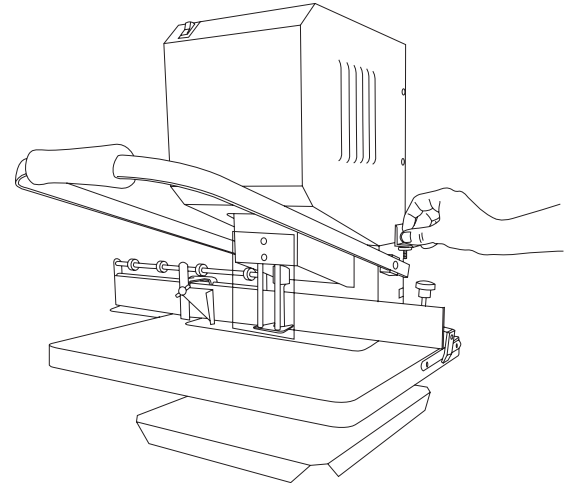

### 4.4 - Adjusting the Back-gauge

- 4.4.1** Adjust the Back-gauge so that it is the correct distance from the edge of the product to the center of the hole to be drilled by performing the following:
- 4.4.2** Loosen the Clamp Knob on the right side of the Back-gauge.
- 4.4.3** Using the two (2) Scales embedded in the rear corners of the table, align the front edge of the Back-gauge with the desired distance.
- 4.4.4** Zero (0) on these scales align with the center of the hollow drill bits.
- 4.4.5** Tighten down the Clamp Knob when the Back-gauge is positioned as desired.

Diagram 4-40

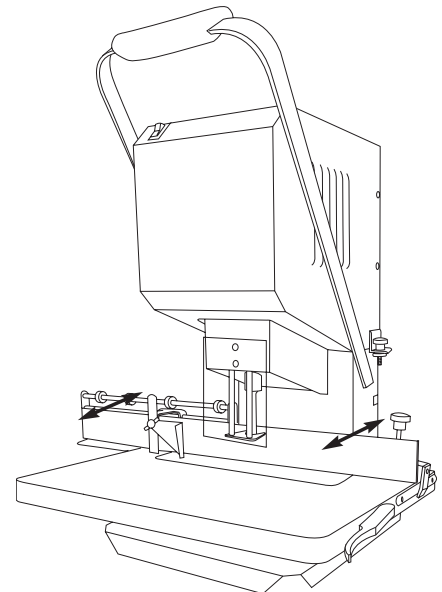

## 4 - Operation

### 4.5 - Drilling Procedures

- 4.5.1** When you are ready to drill, set the product to be drilled on the table and make sure it is secure using the Paper Side Stops. Turn the machine on and holding the product firmly in place with one hand, pull down on the Handle raising the Table up to meet the drill bit. Using one consistent smooth stroke, put pressure on the Handle so that the Table rises fully allowing the drill bit to drill through the product. It is important you maintain a consistent speed through the entire stack. It is also important you do not go too slow or too fast. If you drill too slow you can burn the paper leaving undesired marks. If you drill too fast, the drill bits will act more like a punch and they will break or plug.

Diagram 4-50

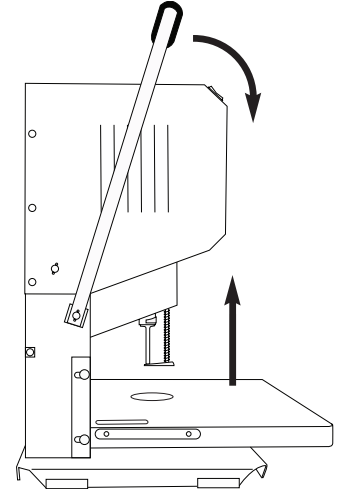

### 4.6 - Tips on Drilling

- 4.6.1** Use a sharp drill bit at all times... Using a drill bit sharpener, sharpen your drill bits regularly. Apply light pressure when sharpening. Too much pressure may cause flaring of the tip. (Once a drill bit has a flared tip, it becomes defective.)
- 4.6.2** Sharpening Stone... Use to debur the outside cutting edge of the drill bits for better performance.
- 4.6.3** Lubricate drill bits occasionally... Use Drill-Ease or Spin-Eze. While the drill is running, simply touch the Drill-Ease stick to the drill bit or brush on the Spin-Eze. Drill through scrap to remove any excess. This will allow for a smoother cut.
- 4.6.4** Drill Block...When drilling, a drill bit must stop slightly above the drill block. Replace worn out drill blocks regularly to ensure proper drilling.

## 5 - Maintenance

### 5.1 - Safety



**ALWAYS DISCONNECT THE POWER BEFORE PERFORMING MAINTENANCE ON THIS MACHINE. MAINTENANCE SHOULD ONLY BE PERFORMED BY A QUALIFIED TECHNICIAN.**

### 5.2 - Annual Lubrication

- 5.2.1** Lubricating your EBM-S should be done at least once every 12 months; however, it may be necessary to lubricate more often depending on use. Whenever the Table starts becoming difficult to lift, it may be time to lubricate.
- 5.2.2** Insert an oil can (not provided) into the hole on the rear panel just below the Chip Chute. This hole provides direct access to the lift pin. Lubricate the lift pin with a light machine oil.

*Diagram 5-10*

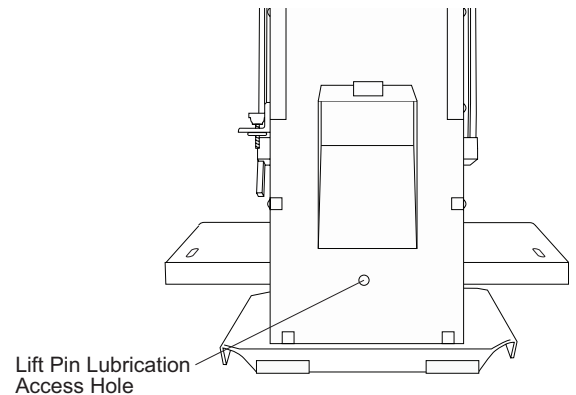

## 6 - Trouble Shooting Guide

### 6.1 - Determining the Cause and Correction to Certain Problems

Problem	Cause	Correction
Drill bit not concentric.	Foreign material in chuck or in drill plug.	Inspect and clean.
	Drill bit is bent.	Replace drill bit.
	Drill bit not seated in chuck properly.	Reinsert drill bit correctly.
	Chuck is not tight to spindle.	Tighten set screw.
Drill bit not drilling.	Drill bit plugged.	Remove and clear chips. Check for other foreign matter.
	Drill bit dull.	Sharpen drill bit.
	<b>Note:</b> In extreme conditions, the drill chuck and/or chip chute may be plugged. Remove the drill bit, loosen the chip chute, pull down, and clean. See <i>Operating Instructions</i>	
Table lift system lifts unevenly or is noisy.	Ball bushings in lift system dry or worn.	Lubricate or replace.
	Lift pin damaged.	Replace lift pin.
Machine vibrates, wobbles, resonates, etc.	Drive motor loose.	Tighten.
	Machine is sitting on uneven surface.	Reposition drill to obtain concentricity
	Drill bits are out of concentricity.	Reinstall drill bits to obtain concentricity.
Drill bit drills into drill block/drill bit not drilling through bottom sheet of paper.	Drill bit was not adjusted to card stock/card stock not used.	Adjust per <i>Operating Instructions</i> .
	Operator not allowing full travel of table.	Drill per <i>Operating Instructions</i> through full drilling cycle.
Table pivots front and back.	Table guides are out of adjustment.	Loosen the two screws holding the table guides located on the sides of the upright and readjust.

# 7 - Parts Diagrams

## 7.1 - Front, Rear, and Side Views

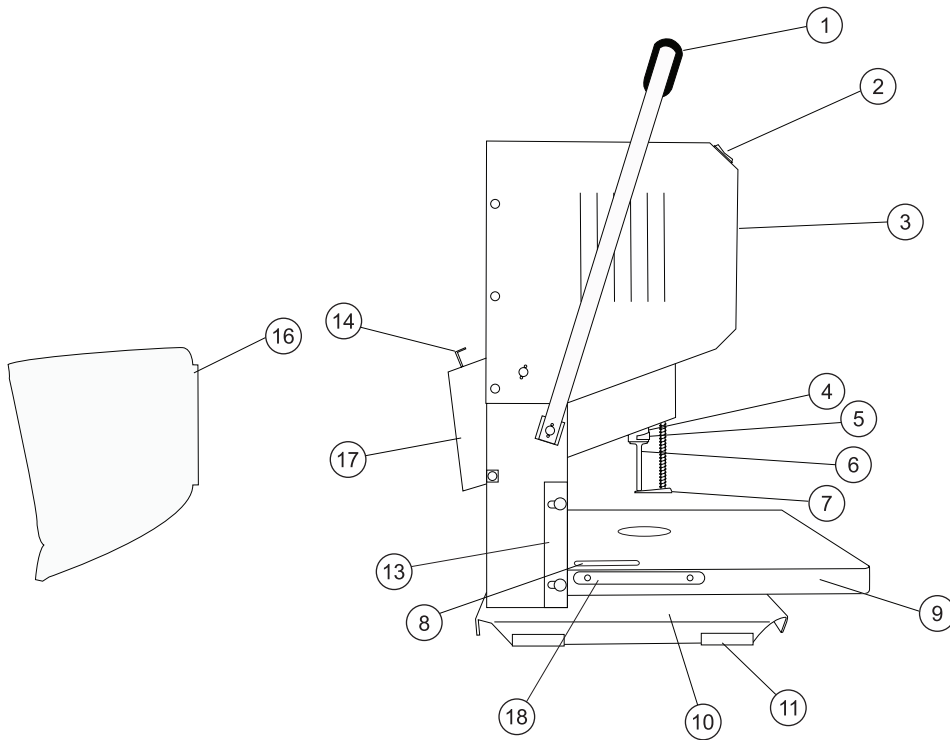
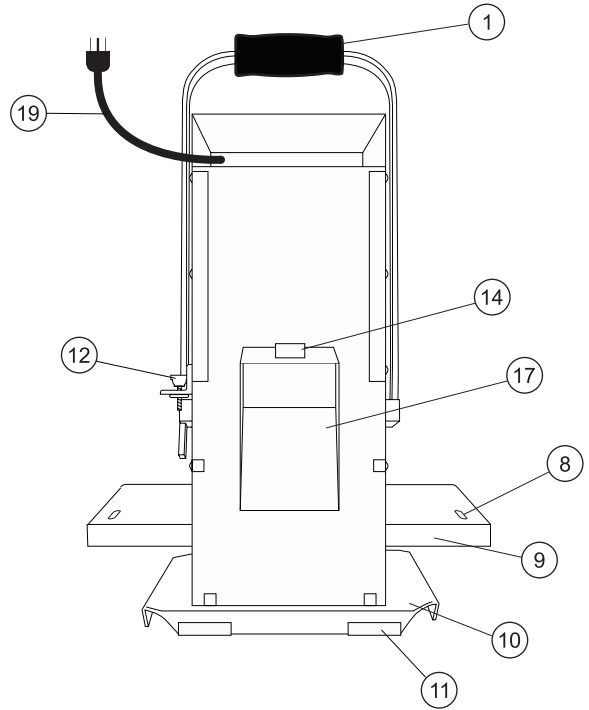
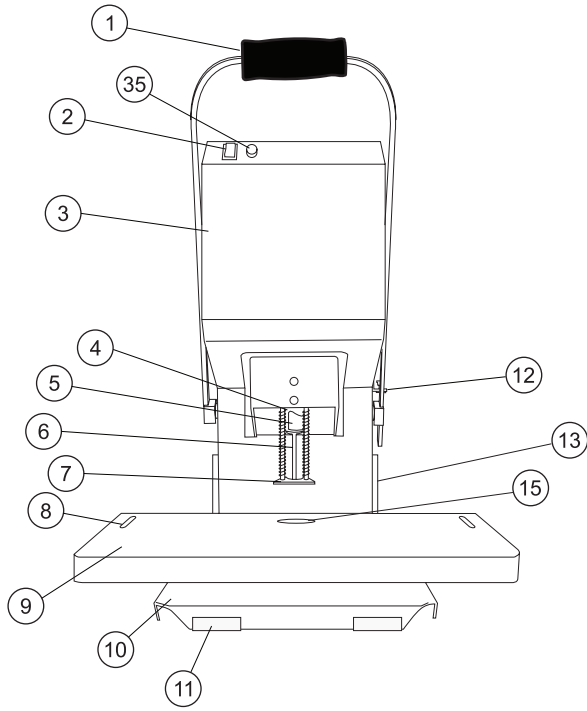

# 7 - Parts Diagrams

## 7.2 - Internal Views and Table Assembly

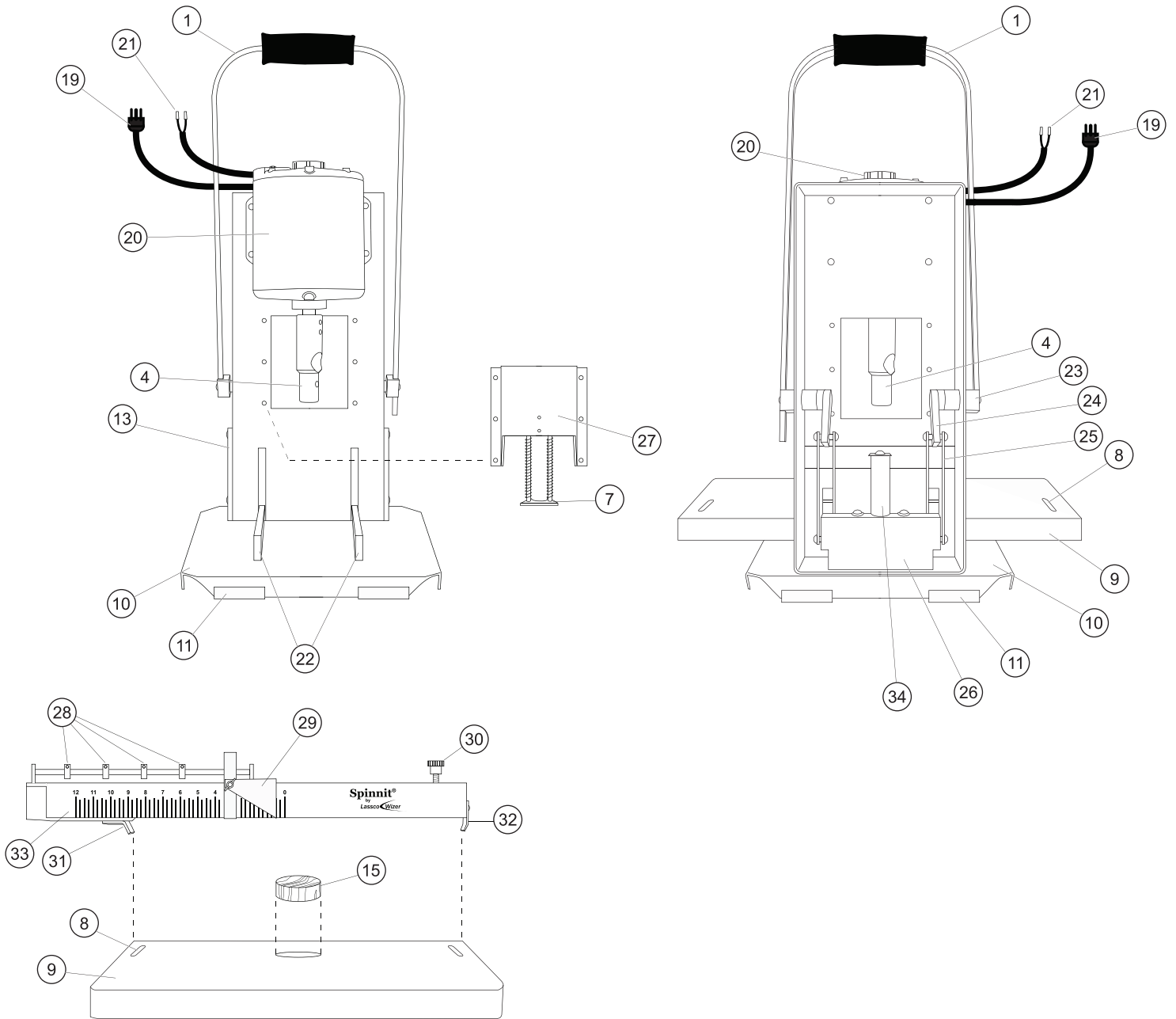

# 7 - Parts Diagrams

## 7.3 - Parts List

- ① EZ-108A: Handle Assembly
- ② FM5-5006: Rocker Switch (On/Off)
- ③ EZ-117A: Shroud Assembly
- ④ FM5-5003: Chuck
- ⑤ FM5-5011: Chuck Release Guard
- ⑥ Hollow Drill Bit
- ⑦ EBM2-0111A: Pressure Foot Assembly
- ⑧ 3S-14: Table Scales
- ⑨ EBMS-114A: Table Assembly
- ⑩ EZ-1025: Base
- ⑪ EBM-44A: Channel Guard
- ⑫ EBM-20A: Table Height Adjustment Assembly
- ⑬ EZ-1034: Table Guide
- ⑭ EBM2-1047: Chip Bag Bracket
- ⑮ EBM-10: Drill Block
- ⑯ EBM2-1048: Chip Bag
- ⑰ EBM2-110A: Chip Chute Assembly
- ⑱ FM4-4003: Side Iron
- ⑲ FM5-5008: Power Cord
- ⑳ FM5-5002: 1/4 HP Motor
- ㉑ Wire Harness
- ㉒ EZ-1024: Fork
- ㉓ EBM2-1019: Pivot Hub
- ㉔ EBM2-103A: Pivot Arm Set Assembly
- ㉕ EZ-1026: Lift Bars
- ㉖ EZ-1023: Lift Pin Housing
- ㉗ EBM2-111A: Housing Assembly
- ㉘ EBM-47: Stop Collars
- ㉙ EBMS-800B: Paper Side Stop Assembly
- ㉚ 1/4-20 x 2-1/4" Thumbscrew
- ㉛ EBMS-10: Back Gauge Clamp
- ㉜ EBM-38B: Adjustable Clamp Finger
- ㉝ EBMS-8008: Back Gauge Scale
- ㉞ EBM2-1000: Lift Pin
- ㉟ EBM-82: 6 Amp Fuse