

HEDMAN®

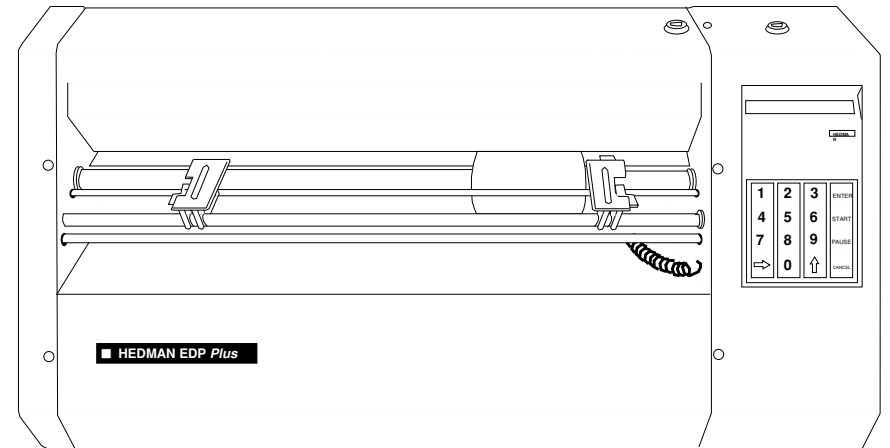

OPERATING INSTRUCTIONS

EDP *Plus*

**PROGRAMMABLE
CONTINUOUS
FORM SIGNER**

Your Continuous Form Signer is fully assembled except for the ink roll, which must be installed before operating the signer. Refer to Page 9, Figure 10, for ink roll installation instructions.

**PLEASE BE SURE THAT YOU CAREFULLY
READ ALL INSTRUCTIONS
BEFORE OPERATING YOUR HEDMAN CHECK SIGNER.**

Your Key Number:ON/OFF _____
COVER _____
ON/OFF/PROGRAM _____
Machine Serial Number _____

ACCOUNTS

- | | |
|----------|-----------|
| 1. _____ | 6. _____ |
| 2. _____ | 7. _____ |
| 3. _____ | 8. _____ |
| 4. _____ | 9. _____ |
| 5. _____ | 10. _____ |

Manufactured by: THE HEDMAN COMPANY
189 Gordon Street
Elk Grove Village, IL 60007-1118
(847)718-6500
FAX (847)718-0603
© 1993 The Hedman Company

Manufactured by: THE HEDMAN COMPANY
189 Gordon Street
Elk Grove Village, IL 60007-1118
(847)718-6500
FAX (847)718-0603

Printed in U.S.A.
Form No. 198483HF (Rev.A)

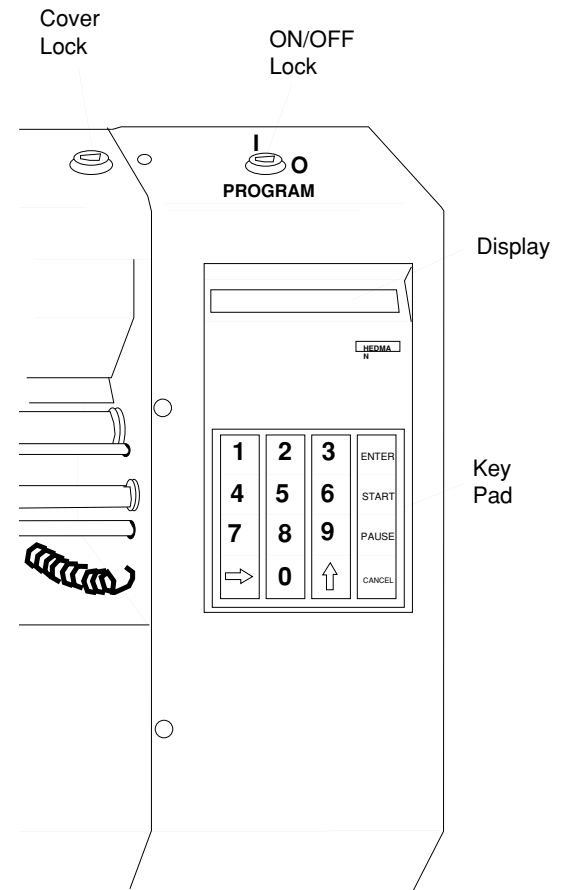

Figure 1

A. OPERATING INSTRUCTIONS

1. Plug unit into a properly grounded outlet.
2. Unlock cover lock and open top cover. Insert two signature plates as described on Page 4. Close top cover and relock.

TURN UNIT ON

3. Unlock the ON/OFF lock located over the display by turning key counterclockwise to the ON position. The following screen will appear for 10 seconds:

<p>EDP Plus XX.XX mm / dd / yy ©1993 The HEDMAN Company</p>
--

The version number and date are used to identify the software provided with the unit.

PASSWORD

•If a **password is not required** the following screen will not appear, proceed directly to Step 6.

•If a **password is required** the following screen will be displayed:

4. Press [1] thru [10] digit keys to enter password. An "*" will appear on the display for each digit entered. Press [Cancel] to cancel an entered number. Press [ENTER] to enter a keyed password.

```
Password :
[ENTER] To Accept
```

5. If the password is not valid press [CANCEL] to return to Password screen.

```
ACCESS DENIED
Press [CANCEL]
```

SELECT ACCOUNT

The following screen will appear when a password is accepted or if a password is not required it will appear when machine is turned on.

6. Either press [ENTER] to accept Account 1, or press [2] thru [10] and then [ENTER] to select another account. Press [CANCEL] to cancel an entered number.

```
Select Account Number 1
[ENTER] To Accept
```

READY

The following screen will appear after [ENTER] has been pressed.

```
Account ## Batch 0
READY      Audit #####
```

SIGNING FORMS

7. Load forms as described on Page 5. Check that the leading edge does not protrude into the opto sensors. Press [START] to begin signing.

```
Account ## Batch #####
SIGNING   Audit #####
```

PAUSE

8. Press [PAUSE] to temporarily stop signing forms. Press [START] to resume signing.

```
Account ## Batch #####
PAUSED    Audit #####
```

NOTE: *If the signer remains in [PAUSE] longer than four (4) minutes it will go to [FINISHED] as described in Step 9. To restart, the forms must be removed from the signer. Then press [CANCEL] or [ENTER] to return to the Select Account screen as shown in Step 6.*

FINISHED

9. When forms run out or when [CANCEL] is pressed the machine will stop.

Account ##	Batch #####
FINISHED	Audit #####

10. Press [CANCEL] or [ENTER] to return to the Select Account screen shown below. The [CANCEL] key can also be pressed when there is a machine problem or when a mistake is made when entering information.

Select Account Number 1
[ENTER] To Accept

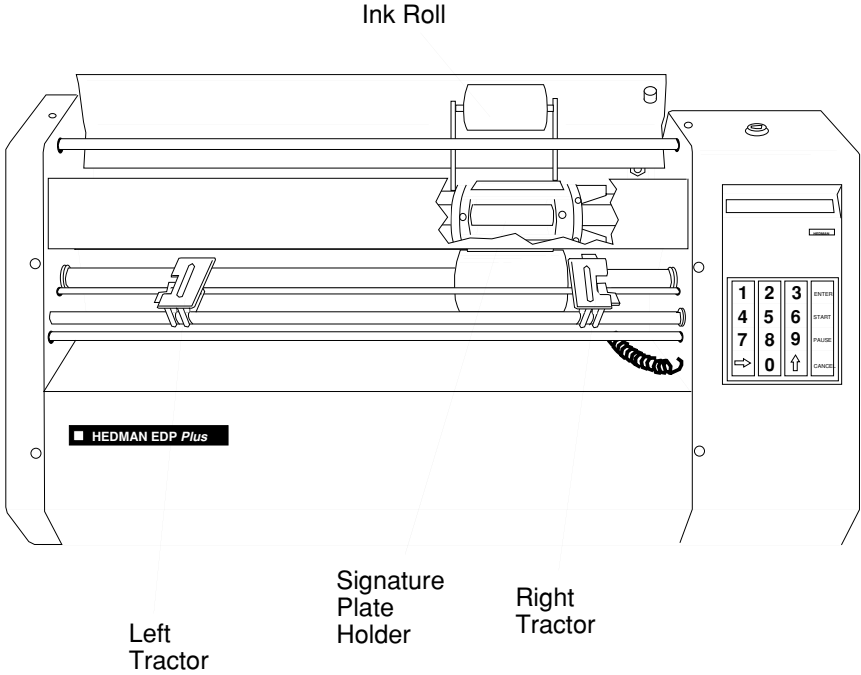

Figure 2

B. LOADING SIGNATURE PLATES

The signature plate holder on your machine has positions for two(2) signature plates. To sign forms you must use two (2) signature plates.

1. Insert the Cover key into the Cover lock, turn it clockwise to open the cover.(See Figure 1)
2. Grasp the signature plate with your left hand - - the notch should be pointed to the left.(See Figure 3)
3. Slide the signature plate down, sliding it to the left so that the plate holder pin locates into the signature plate notch.

Figure 3
Inserting
Signature
Plate

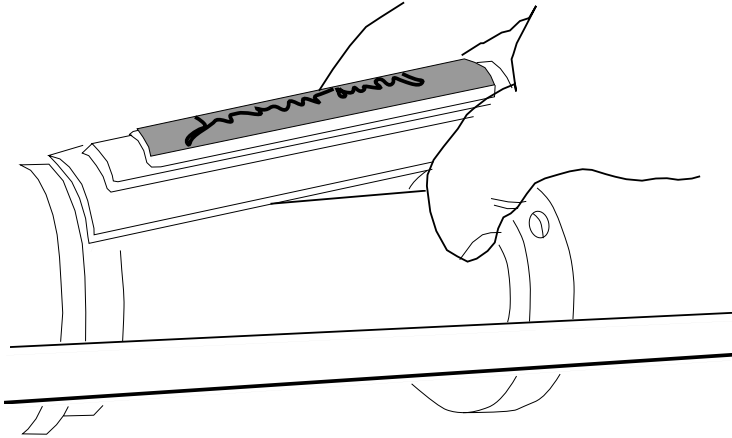

4. Holding the signature plate with your left hand, use your right index finger (or the eraser end of a pencil held in your right hand) to press down on the signature plate holder latch. (See Figure 4)
5. Press the signature plate down into position and release the latch. The latch will position itself into the beveled slot on the signature plate and lock the plate firmly into position.
6. Load the second signature plate by manually rotating the signature plate holder and repeating Steps 2-5.

Figure 4
Latching
Signature
Plate

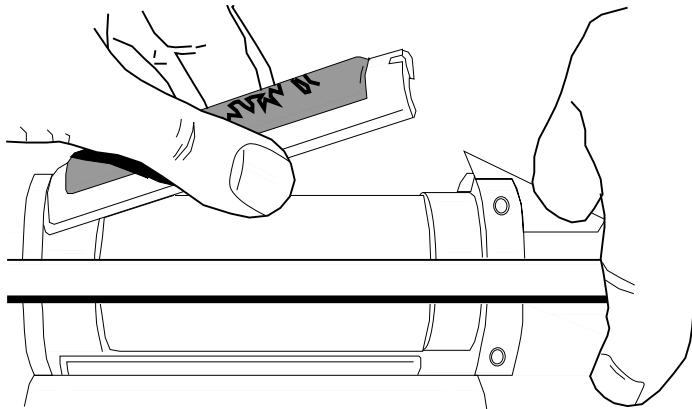

C. LOADING AND POSITIONING OF CONTINUOUS FORMS

1. Open left and right tractor covers.
2. Align the top right edge of the continuous form with top edge of right tractor. Align form carrier strip holes with tractor pins making sure leading edge of paper does not protrude into opto sensor. Close right tractor (refer to Figure 5).

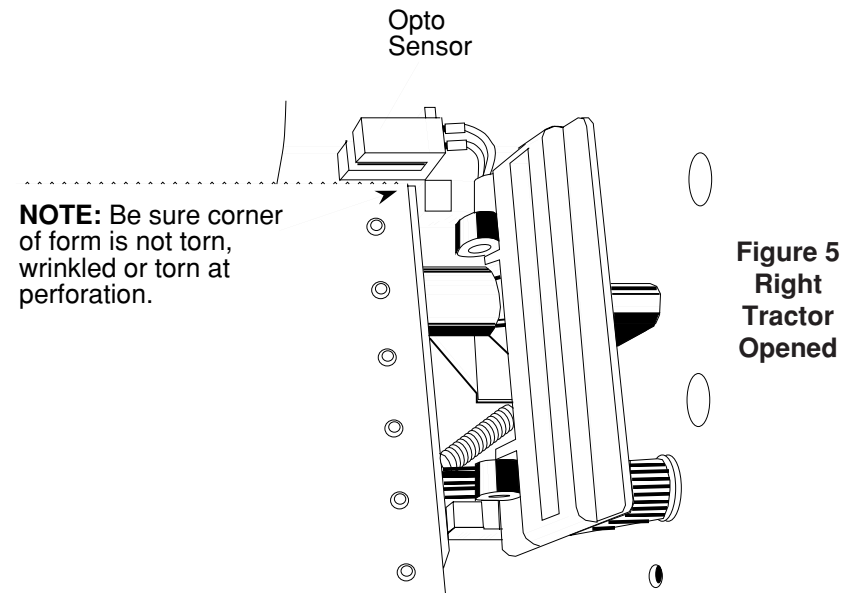

3. Release left tractor lock by lifting up on locking lever (refer to Figure 6).

Figure 6
Unlocking
Left
Tractor

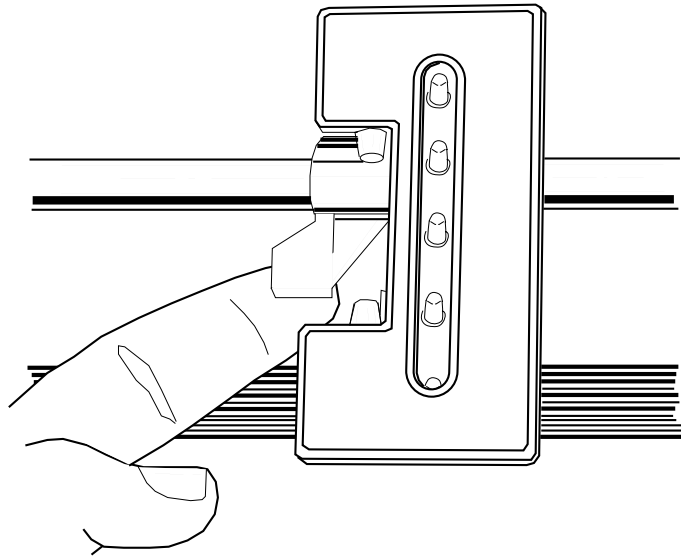

4. Using both hands, one on the **LEFT** tractor the other on the paper, slide tractor right or left so that the tractor pins line up with holes in form carrier strips (refer to Figure 7).
 - a. Align top of form with top of tractor - - insert left form carrier strip into feeder pins and close tractor lifting cover (See Figure 7)

Figure 7
Lining-Up
Left
Tractor

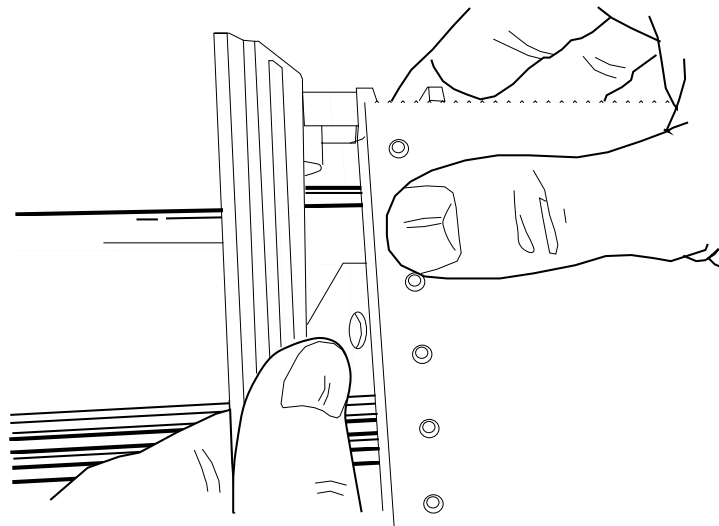

- b. **GENTLY** pull tractor to the left to eliminate any sagging of the forms - - - forms must be taut between the tractors. Lock the left tractor in place by pushing down on the locking lever. (See Figure 8)

Figure 8
Locking
Left
Tractor

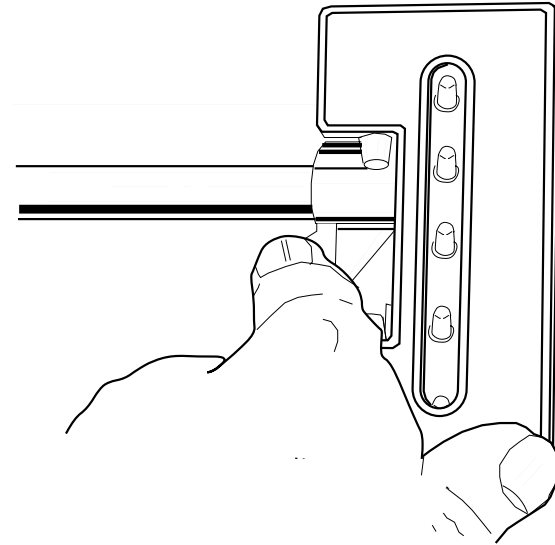

NOTE: Continuous forms of some manufacturers may vary in width from box to box or even within the same box. Whenever loading continuous forms, always check to make sure that the feeder strips line up with the tractor pins **AND** that the paper is taut between the tractors.

5. Close cover on machine. **LOCK** and **REMOVE** key.
6. Press [ENTER] and then [START] and allow approximately 12 forms to run through the machine. Press [PAUSE].
 - a. Make sure that the checks are stacking properly at the rear of the machine. The first form should be pointing toward the rear of the machine. If not, manually refold the forms along the natural fold lines. Place the stack of refolded forms about 6" from the rear of the machine.
 - b. Press [START] and sign forms. The machine will stop automatically when the last form has been signed.

FOR AN OPTIMUM SIGNING OPERATION IT IS SUGGESTED THAT:

- A STACK OF FORMS NO HIGHER THAN 4" BE PROCESSED IN ONE RUN.
- THE SIGNER BE MOUNTED ON A SUITABLE STAND THAT ALLOWS THE SIGNED DOCUMENTS TO "DROP" FREELY BELOW THE BASE OF THE SIGNER

D. INKING SYSTEM

Your Continuous Form Signer is equipped with an ink roll that will sign up to 150,000 signatures, depending upon age and usage. The ink roll is located inside the top cover.

CAUTION: Do Not touch ink roll.

1. INK ROLL PRESSURE

The ink roll must not place too much pressure on the signature plates. Adjust the ink roll to just "kiss" the signature plates but with enough pressure for a good printed impression. Ink roll pressure is adjusted by turning the **RED** adjustment knob located at the rear of the form signer (See Figure 9). Turning this knob to the right **DECREASES** ink roll pressure - a lighter signature imprint. Turning the knob to the left **INCREASES** ink roll pressure - a darker signature imprint.

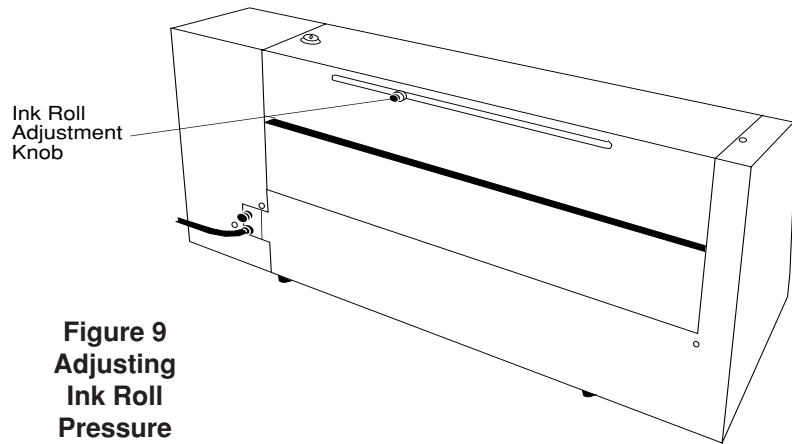

**Figure 9
Adjusting
Ink Roll
Pressure**

2. POSITIONING INK ROLL

The ink roll can be moved by opening the top cover and simply sliding the ink roll assembly to the right or left as required (See Figure 10). The ink roll must be positioned so that it inks the entire signature plate.

3. REPLACING INK ROLL

- a. Open the top cover.
- b. Put on the gloves shipped with the ink roll.
- c. Pull the cotter pin out of the axle (see Figure 10).
- d. Hold onto the ink roll and pull the axle out of the ink roll carriage.
- e. Hold the new ink roll between the sides of the ink roll carriage and insert the axle with the pointed end as shown in Figure 10.
- f. Insert the straight side of the cotter pin into the hole in the pointed end of the axle.
- g. Push the cotter pin until the axle is secured between the two loops of the cotter pin.
- h. Close the top cover.

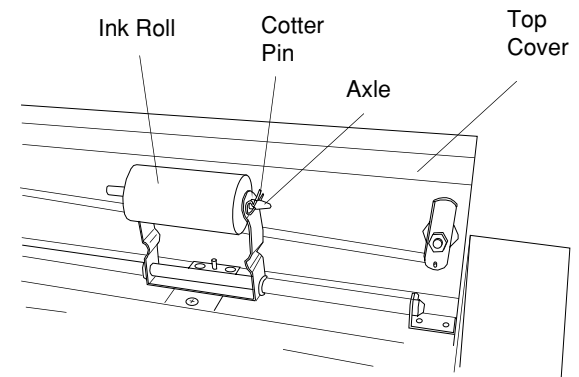

Figure 10

E. COUNTING

Each account has its own batch counter and audit counter which are displayed when documents are being signed. The audit counter displays the total number of documents that have been signed in that account and is not resettable. The batch counter displays the number of documents that were signed in the last group of documents processed. It will automatically reset to zero when a new run of documents is processed in the current account selected, or when a new account is selected.

F. PAPER MISFEED

NOTE: *Torn or damaged carrier strips can cause misfeeds or stop the machine from operating. Check the carrier strips on the forms to make sure they will not cause a problem. Should a paper misfeed occur, the following steps should be followed:*

1. Stop machine by pressing [CANCEL].
2. Unlock and open cover
3. Open tractor cover. Clear and remove forms.
4. Examine damaged carrier strips and make any necessary repairs with scotch tape, taking care not to cover carrier strip holes.
5. Reload forms in tractors. First form should be undamaged or repaired.
6. Close and lock cover and remove key.
7. Press [ENTER] to accept Account 1 or press [2] thru [10] and then [ENTER] to select another account. Press [START] to begin signing.

TROUBLESHOOTING

SYMPTOM	CAUSE
Machine will not run continuously.	<ol style="list-style-type: none">1. Forms not loaded into tractors properly.2. Cover is not locked and key removed.
Machine will not operate.	<ol style="list-style-type: none">1. ON/OFF key not in ON position.2. Check wall plug.3. Check fuse (rear of machine). Replace with 3 AMP fuse.4. Remove continuous form from tractors. Turn ON/OFF key to OFF position and then back to ON position. Reload continuous form into tractors.
Signature not properly positioned on form.	<ol style="list-style-type: none">1. Check that continuous form is not torn or wrinkled.2. Check that proper Account is selected.

HELP CODES

If a help code should appear during operation take the following action. If help code re-appears after you have taken the suggested action, call for service.

HELP 1 START button pressed with paper in sensor.

**HELP 1: Paper Sensor
Blocked Press [ENTER]**

ACTION: Remove and reload forms as described on Page 5. Press [ENTER] and then [START] to start signing.

HELP 2 Cannot find home flag at start.

**HELP 2: Signature Shaft
Home Flag Not Found**

ACTION: Check to see that the signature shaft rotates freely. Press [CANCEL] then press [ENTER] and then press [START]. If HELP 2 appears again call for service.

HELP 4 Top cover open.

**HELP 4: Signature Plate
Cover Is Open**

ACTION: Insert key in top cover lock as shown in Figure 1 and lock cover.

HELP 5 No paper sensed.

**HELP 5: No Paper Found
Check Paper Feed**

ACTION: Check to see if forms are correctly loaded into the machine. If they are, remove and reload forms. Press [CANCEL], then [ENTER] and then [START] to begin signing.

HELP 9 Printing stopped by power failure.

**HELP 9: Printing Stopped
By Power Loss**

ACTION: Correct the power problem. Press [CANCEL] and record audit and batch counter values.

HELP 11 Invalid number entered.

**HELP 11: Invalid Value
Range: 1 To 10**

ACTION: Verify that the number you have entered is between 1 and 10 and then re-enter the number.

If a HELP 6, HELP 7, HELP 12, HELP 14, HELP 15, HELP 16 or a HELP 17 appears, call for service. There is no corrective action you can take and attempting to operate the machine may result in damage or loss of data.