

## W115 Flat/Saddle Stapler

### Use Only skrebba® Heavy Duty Staples

Size	Sheet Capacity*	Item ID
1/4" (23/6)	02 - 15 sheets	W118-D
5/16" (23/8)	15 - 35 sheets	W118-A
3/8" (23/10)	35 - 55 sheets	W118-E
1/2" (23/12)	55 - 75 sheets	W118-B

\*Sheet capacity is measured using 20 lb stock

### Loading Staples

1. Open the staple magazine until it reaches its stop.
2. Insert a full strip of staples (up to 200 staples)
3. Push the staple magazine back in until it latches

**Note:** If the magazine is not securely latched, staples will not be released.

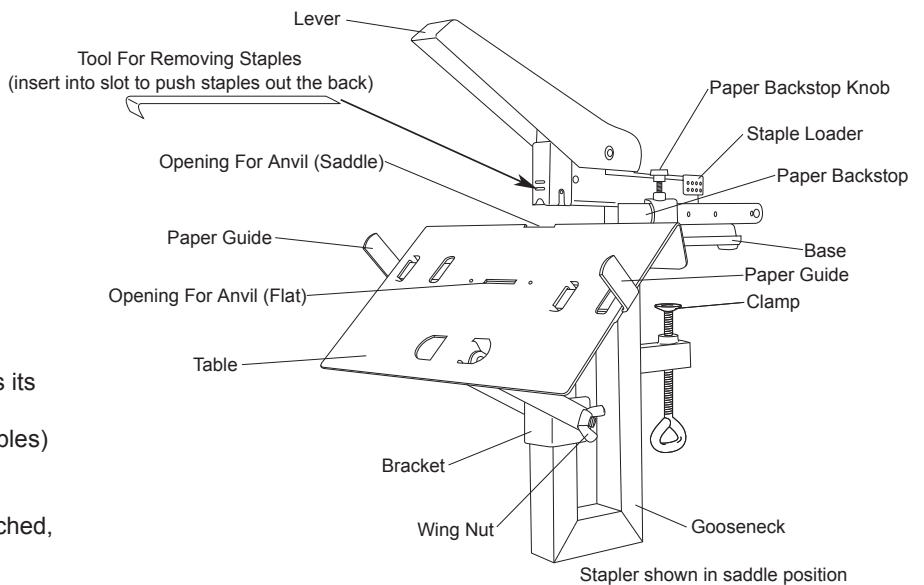

### Flat Stapling

1. Loosen the Wing Nut on the right side of the Gooseneck.
2. Lift the Table and slide back towards the stapling head so that the Opening For Anvil (Saddle) fits into the tab extending from the Base. (Note: The Bracket on the Gooseneck will slide up to allow for flat stapling)
3. Push back into the tab on the base, then down over the anvil.
4. Once the table is in position for flat stapling, the anvil must be seen through the Opening For Anvil (Flat), at the center of the table.
5. Tighten the wing nut.
6. Adjust the Paper Backstop as desired for the appropriate throat depth.

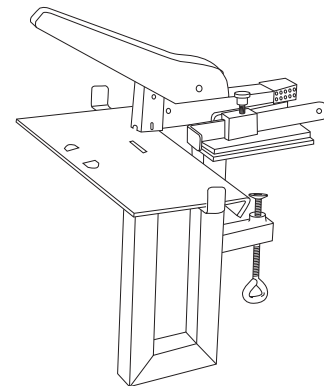

### Saddle Stapling

1. Loosen the wing nut on the right side of the gooseneck.
2. Lift the table and slide it forward and down (away from the stapling head) so that the anvil fits into the opening used for saddle stapling. (Note: The Bracket on the Gooseneck will slide down for saddle position).
3. Center the table over the anvil in the saddle position.
4. Tighten the wing nut.

**Caution:** To avoid injury, do not place fingers on the anvil or under the stapling head.

#### Note: In case of a staple jam...

Put the stapler in the Flat Stapling position. Place a 1/2" tall block of wood (not provided) on the table underneath the stapling head with-out blocking the opening where the staples dispense. Press down on the Lever until the jammed staple is removed.

Made In Germany

Lassco Wizer

485 Hague Street, Rochester, NY 14606 U.S.A.  
Tel: 585-436-1934 Fax: 585-464-8665  
www.lasscowizer.com info@lasscowizer.com